

CLARION UNIVERSITY OF PENNSYLVANIA

a member of the

STATE SYSTEM OF HIGHER EDUCATION

REQUEST FOR PROPOSAL

Multi-Media Classroom Systems

and

AV Equipment / Installation Pricing

For Clarion University and Edinboro University

NOTICE TO CONTRACTORS

The State System of Higher Education invites you to submit a sealed bid proposal for Design, Installation, Support of Classroom System Multi-Media Equipment, for Clarion University and Edinboro University, otherwise referred to as "Clarion", "Edinboro" or "the Universities", a member of the State System of Higher Education herein referred to as "the System".

Sealed proposals, provided in strict compliance with requested specifications, as noted to insure acceptance, will be received at the 210 Carrier Administration Purchasing Office, Clarion University, 840 Wood Street, Clarion, PA 16214 not later than **2:00 p.m., January 13, 2012**. All sealed proposals must be valid for a minimum of ninety (90) days from the bid due date above.

Purchasing Section 1

GENERAL

1.1 Overview

This request for proposal (RFP) provides interested suppliers with sufficient information to prepare and submit proposals for consideration with the intent of contracting to provide the services described herein.

Clarion University and Edinboro University of Pennsylvania are requesting firm pricing from providers, herein referred to as "the Contractor(s)", who are offering their services, with detailed comparisons between requested specifications and those of their own. Respondents are encouraged to provide enhancements to the specifications.

Instructions for proposal submissions, a description of services to be provided in accordance with the project specifications, and general evaluation criteria are contained herein. This RFP is to be distributed to a range of applicable suppliers able to provide the services required.

This contract will be awarded to the Contractor(s) judged to be the best meeting or exceeding the requirements as specified. General information about both Universities, including campus maps, may be obtained by visiting www.clarion.edu and www.edinboro.edu.

1.2 General Conditions and Specifications

POINT OF CONTACT: The point of contact for this RFP is Robin Bish Purchasing Agent II, Clarion University of Pennsylvania, Phone: (814) 393-2233, e-mail robish@clarion.edu, Fax: (814) 393-2015. It is preferable that all questions are received via e-mail or fax.

1.3 Bid Opening Date: January 13, 2012 2:00 PM– 210 Carrier Hall

1.4 Incurring Costs

Clarion is not liable for any cost incurred by the supplier for preparation of the RFP or costs incurred prior to award of a contract.

1.5 Contract Expectations

The selected supplier(s) will be expected to execute the terms of a standard "blueback" contract (see Attachment B), considered to be an official Clarion University contract. The chosen Contractor's terms and conditions, if present, will be attached to the contract and/or referenced and considered to be incorporated into the contract document.

1.6 Fiscal Condition

At all times this RFP and any subsequent contract(s) shall be conditional upon the availability of the fiscal budget.

1.7 Contract Length

The contract will be in effect for a period of two years with 3 years renewable from the effective date assigned by the Contracting Officer until December 30, 2015

The Commonwealth reserves the right, upon notice to the Contractor, to extend the term of the Contract for up to three (3) months upon the same terms and conditions. This will be utilized to prevent a lapse in Contract coverage and only for the time necessary, up to three (3) months, to enter into a new contract.

1.8 Response Copies

Respondents must submit six (6) printed and one (1) electronic copy of the RFP University prior to the opening. **The cost portion of the proposal must be bound and sealed separately from the remainder of the proposal.**

1.9 Taxes

The Commonwealth is exempt from all excise taxes and all transportation taxes imposed by the Internal Revenue Code. Sales made to the Commonwealth are exempt from the provisions of the Fair Trade Law and the Pennsylvania Sales Tax. No tax shall be included in the bid price.

1.10 E-mail Address Request/Acknowledge of Receipt

Respondents are requested to provide an acknowledgement of receipt and an appropriate e-mail address and/or fax number immediately upon receipt of this RFP. Any changes in dates, dissemination of addendum to this RFP, etc. will be issued through e-mail or fax communications.

Address your acknowledging e-mail to robish@clarion.edu.
or fax (814)393-2015.

1.11 Response Format

Each comment and/or response to this RFP must be indexed in the exact same order as written. Deviations from this required response format may result in the rejection of part or all of the bid submission. **The cost portion of the proposal must be bound and sealed separately from the remainder of the proposal.**

1.12 Conditional Price Escalations

Conditional Price Escalations.

Price increases may be tolerated if in accordance with the following statements:

Escalation of annual costs for subsequent years of this contract is not automatic and shall not exceed inflation guidelines as established by the nationally accepted Consumer Price Index-Urban (CPI) for each year for this particular commodity or service. Contractor must provide documentation to justify escalation and make escalation request in writing on an annual basis.

Should escalation figures prove to be above CPI levels, the contractor must provide sufficient justification for the increase and said increase must be acceptable to the Universities. Newly negotiated labor agreements, federally recognized fuel inflation adjustments, statutory increases, and applicable federal and state wage laws are acceptable increases which may exceed CPI levels.

1.13 Terms and Conditions Exceptions

It is mutually agreed by and between the Universities and the Contractor that the universities will be accepting the supplier's offer through issuance of one or more contracts that shall be an agreement between the parties thereto containing all specifications, and terms and conditions as stated in this Sealed Bid Proposal. The supplier shall clearly state, on the bid response, any exceptions to or deviations from the Terms and Conditions contained herein. Such exceptions or deviations may be considered in evaluating the bids received and may result in rejection of that bid.

1.14 Billing Procedures

When applicable, payments will be made and paid according to the terms and conditions as set forth and agreed upon by both parties.

Itemized invoices to the Universities shall include the purchase order number, contract number, dates of service, types of services provided and equal expected charges as will be delineated in the purchase order.

Invoices will not be paid without proper approval of the Universities designee for these services. University payment terms are Net /30, unless otherwise agreed to by both parties.

Respondents should outline their proposed procedures for handling Clarion University's account and Edinboro University's account provides the name of a person who will be familiar with this contract and the correct billing procedures. The name of the person having overall responsibility for Clarion University's and Edinboro University's account should also be included.

1.15 Hold Harmless Provision

The Contractor shall hold the Commonwealth harmless from and indemnify the Commonwealth against any and all claims, demands and actions based upon or arising out of any activities performed by the Contractor and its employees and agents under this Contract and shall, at the request of the Commonwealth, defend any and all actions brought against the Commonwealth based upon any such claims or demands.

1.16 Insurance

The Contractor must provide public liability insurance. Amounts of such insurance are suggested to be no less than \$1,000,000 for any particular loss for any one person, including property damage, and not less than \$1,000,000 for any one accident involving injury, including wrongful death to more than one person including property damage. Additionally, the Contractor is responsible for all Workmen's Compensation Insurance requirements as dictated by Federal and State statutes.

1.17 Termination of Agreement

The Commonwealth has the right to terminate the Contract for any of the following reasons. Termination shall be effective upon written notice to the Contractor:

(a) Termination for Convenience. The Commonwealth shall have the right to terminate the Contract for its convenience if the Commonwealth determines termination to be in its best interest. The Contractor shall be paid for work satisfactorily completed prior to the effective date of the termination, but in no event shall the Contractor be entitled to recover lost profits.

(b) Non-appropriation. The Commonwealth's obligation to make payments during any Commonwealth fiscal year succeeding the current fiscal year shall be subject to availability and appropriation of funds. When funds (state and/or federal) are not appropriated or otherwise made available to support continuation of performance in a subsequent fiscal year period, the Commonwealth shall have the right to terminate the Contract. The Contractor shall be reimbursed for the reasonable value of any nonrecurring costs incurred but not amortized in the price of the supplies or services delivered under this Contract. Such reimbursement shall not include loss of profit, loss of use of money, or administrative or overhead costs. The reimbursement amount may be paid from any appropriations available for that purpose.

(c) Termination for Cause. The Commonwealth shall have the right to terminate the Contract for Contractor default under paragraph 19, Default, upon written notice to the Contractor. The Commonwealth shall also have the right, upon written notice to the Contractor, to terminate the Contract for other cause as specified in this Contract or by law. If it is later determined that the Commonwealth erred in terminating the Contract for cause, then, at the Commonwealth's discretion, the Contract shall be deemed to have been terminated for convenience under subparagraph (a).

1.18 Right To Know

Please be advised that effective January 1, 2009 all responses to this procurement opportunity are subject to the Pennsylvania Right-to-Know Law, 65 P.S. §67.101 et seq., (Act 3 of 2008). The Right-to-Know Law permits any requestor to inspect and/or copy any record prepared and maintained or received in the course of the operation of a public office or agency that is not subject to the enumerated exceptions under the law. If your response to the procurement opportunity contains a trade secret or confidential proprietary information, you should include with your response a separate signed written statement to that effect. Should your response become the subject of a Pennsylvania Right-to-Know Law request, you will be notified by the procurement office to identify all trade secrets or confidential and proprietary information that is included in your response. The Pennsylvania State System of Higher Education (PASSHE) will then determine whether the claimed trade secret or confidential and proprietary information is subject to disclosure.

1.19 Non-Exclusivity

This RFP and any resulting contract is not exclusive and is intended to be an expedient and efficient means of providing the University's needs for this (i.e. service, installation, etc.) at this location. Additionally, it is the University's intent to be able to assure the campus community that the highest quality services were purchased at the best possible rate.

1.20 Silence of Specifications

The apparent silence of this specification and any supplemental specifications as to any details or the omission from it of a detailed description concerning any point shall be regarded as meaning that only the best commercial/professional practices are to prevail and that only workmanship and materials of first quality and of the correct type, size, and design are to be used. All interpretations of the specification shall be made upon the basis of this statement.

1.21 Bid Rejection

Clarion University and Edinboro University of Pennsylvania reserves the right to reject any or all bids/RFPs for any or all reasons and is not bound to accept the lowest response if that bid is judged contrary to the best interests of the University.

1.22 Notice As To Filing A Bid Protest

1) A bidder or offeror, a prospective bidder or offeror, or a prospective contractor, that is aggrieved in connection with the solicitation or award of a contract under the *Commonwealth Procurement Code*, except

as provided in 62 Pa.C.S.A. § 521 (relating to cancellation of invitations for bids or requests for proposals) may file a protest with the Office of the Chancellor, State System of Higher Education, 2986 North Second Street, Harrisburg, Pennsylvania, 17110.

A copy of any protest must also be simultaneously mailed to the Office of the President of the university that issued the bid solicitation. In the event that the Educational Resources Group (ERG) issued the bid solicitation, a copy of the Protest should be filed with its President. No additional notification need be sent if the Office of the Chancellor issued the bid solicitation.

2) If the protestant is a bidder or offeror or a prospective contractor, the protest must be filed with the Office of the Chancellor at the aforementioned address within seven (7) days after the aggrieved bidder or offeror or prospective contractor knew or should have known of the facts giving rise to the protest. In no event may a protest be filed later than seven (7) days after the date the contract was awarded.

3) If the protestant is a prospective bidder or offeror, a protest must be filed with the Office of the Chancellor at the aforementioned address prior to the bid opening time or the proposal receipt date.

4) If a bidder or offeror, a prospective bidder or offeror, or a prospective contractor fails to file a protest, or files an untimely protest, the bidder or offeror, the prospective bidder or offeror, or the prospective contractor will have waived its right to protest the solicitation or award of the contract in any forum. The State System of Higher Education shall disregard protests that are untimely filed.

5) A protest must state all grounds upon which the protestant asserts the solicitation or award of the contract was improper. The protestant may submit with the protest any documents or information it deems relevant to the protest.

6) Upon receipt of the protest, the Office of the Chancellor will render a decision in accordance with the procedures outlines within the *Commonwealth Procurement Code*, 62 Pa.C.S.A. §1711.1 *et seq.*

Purchasing Section 2.0

SPECIFIC ISSUES RELATIVE TO THIS RFP

2.1 Bid Submission Instructions

All responses are to be returned in tact including the entire RFP with any comments and required responses in addition to any required attachments. **The cost portion of the proposal must be bound and sealed separately from the remainder of the proposal. It is extremely important that an authoritative signature be applied to bottom portion of the "Request for Quotation" cover form as well as Attachment A, Bid Proposal form and signature page.** All documents must then be placed in an appropriate envelope and mailed to the University with the following information **CLEARLY LEGIBLE** in the lower left-hand corner. This information should read:

SPECIAL SEALED BID RESPONSE:
Collective No. RNB-12-002
Due Date January 13, 2012 2:00 PM

The envelope should be addressed to:

**Robin Bish, Purchasing Agent II
210 Carrier Administration
Clarion University of PA
840 Wood Street
Clarion PA 16214**

2.2 (not applicable)

2.3 Experience, References and Corporate Viability:

The selected Contractor(s) must be a company normally engaged in providing this service. Contractors are to include with their response their qualifications to meet RFP specifications in terms of past and current experience.

Information attesting to corporate growth, reputation, experience, quality of service, quality of support personnel, etc. should be supplied in ATTACHMENT A, Part B – Contractor's Qualification Statement. The selected Contractor may be requested to provide an annual report and/or financial statements attesting to the fiscal viability of the company.

Contractors without past experience with System member institutions must provide a minimum of four (4) references. The System prefers references from educational institutions with a similar environment where the responding firm has supplied the exact or similar services. Include the name and address of the organization, the name(s), titles and telephone numbers of the person(s) to be contacted and a general scope of the services provided.

In addition, contractors should provide the following:

1. Sample VISIO design drawings (video, audio and control system diagrams, and riser diagrams) from four (4) previous projects. Projects should reflect previous installations of smart classrooms or instructional teaching systems.
2. Sample project documentation and program documents that it has rendered for four (4) previous projects.
3. The Contractor shall explain their strategy on providing services as requested in this RFP.
4. Training/certification credentials for Crestron and Extron programmer(s), system design engineer(s), and support engineer(s) within the organization.

5. Provide documentation and explain the audio/video product lines available to be purchased and serviced.

2.4 Evaluation Criteria

The proposals, which are judged to meet or exceed Clarion's and Edinboro's needs, at the most advantageous prices, will be selected for the overall contract.

The bid specifications contained herein are not intended to be exclusionary, but rather a guide for the type of purchase and service we wish to have provided. All proposals will be accepted, reviewed and evaluated, but the Universities reserves the right to accept the proposal or proposals which are judged best to meet or exceed the needs of the Universities. Each proposal will be equally evaluated where pricing is only one consideration and not necessarily the primary deciding factor.

The Contractor should define/identify the approach/means for large volume or multiple projects across same or both campuses as well as strategy for emergency installations needing short turn-around times.

2.5 Evaluation Standards

The Contractor's proposal shall be submitted at the time specified. Designated University staff members at both Universities will evaluate the proposals received and will consider the following factors in recommending award to a qualified firm. These factors are not necessarily listed in order of priority.

- Overall experience, qualifications, and past experience with similar projects.
- References and/or credentials in providing the services.
- Geographic location: Servicing office from Clarion University; and Edinboro University
- Pricing for Clarion and Edinboro classroom installations and equipment as identified.
- Pricing of labor rates for design, installation, and support services as identified.
- Pricing of system and proposed approach for Nursing Simulation Laboratory.
Note: Maybe optionally bid, subcontracted
- System design, documentation, and control for smart classrooms along with the methodology for efficient implementations.
- Vendor business and product lines represented

2.6 Proposed Time Schedule:

Request for Proposal Distributed	December 2, 2011
Pre-Bid Conference 10:00 AM	December 22, 2011
Conference Call (281) 393-2638	
RFP Formal Opening - 2:00 p.m.	January 13, 2012
Trustee Approval (if >\$25,000)	February 7, 2012
Contract Awarded	February 8, 2012
Contract Approvals complete	February 29, 2012

2.7 Contract Awards

Normal routing for awarded contracts, yearly or multi-year, requires that the document(s) be created and mailed to the chosen contractor(s) for signature and returned to the Universities for appropriate signatures at that level. Once signed, documents are then forwarded to:

- a) University legal counsel for review and approval, then
- b) submitted to the State System of Higher Education and/or Office of General Counsel for review if appropriate.
- c) All contracts, greater than \$20,000 are then submitted to the Commonwealth Attorney General for approval and signature, if appropriate, before they are returned to the University and considered to be valid.

Only after these steps have been followed, is a copy of the contract returned to the contractor(s) as official notification to commence services as directed.

2.8 (Not Applicable)

2.9 Collaborative Procurement Partnership

PASSHE recognizes the significant advantages of collaborative purchasing efforts along with the importance of promoting strong relationships with other educational institutions, local intermediate units, associated school districts, and other not-for-profit and governmental organizations; therefore, purchasing opportunities/terms in this bid document may be extended to these entities.

Purchasing Section 3.0

3.1 Purpose/Scope:

Clarion and Edinboro recognizes the advantages of collective purchasing agreements and the discounts achieved through a joint RFP process. Over the next three to five years, Clarion and Edinboro anticipates a strong demand for the installation of smart classroom and audio/video equipment along with a growing need for related support services. The purpose of this RFP is to establish a multi-year contract for the purchase of technology enhanced "smart" classrooms, A/V equipment, and hourly labor rates for multi-media installation, programming, and repair services.

Clarion anticipates the need to install/refresh over 40 classrooms with updated smart classroom components over the next three year period, in addition to annual maintenance items and accessories such as lamp bulbs to sustain operations. A new multi-media Nursing Simulation Laboratory is being planned for installation during July/August of 2012 at our Venango campus location. This RFP includes design and installation for the Simulation Lab A/V components (see Nursing Simulation Lab – Requirements and Pricing section).

Edinboro anticipates the need to install/refresh over 10 classrooms with updated smart classroom components over the next three years, in addition to annual maintenance items and accessories such as lamp bulbs to sustain operations.

In addition to the pricing structure listed below, it is strongly recommended that bid responses include a pricing matrix which identify additional volume levels and discounts. This type of matrix will offer an incentive to establishing a multi-year contract agreement extension in year two and year three.

Classroom System – Design and Installation Requirements

3.2 Classroom System Design

The Contractor shall propose a detailed design and costs for smart classroom system installation(s) with the following listed capabilities: Clarion System, and Edinboro System. The proposed system shall be cost-effective, simple to operate, and reliable. Contractor shall provide references of previous installations with contact name, address, and phone number. The Contractor can propose costs for more than one system (i.e. University base system and advanced system). Power and network connections will be provided at the designated locations by the University. Documentation shall be provided for the system design, including VISIO (ONLY) wiring diagrams, equipment cut-sheets and costs to install the system(s). As technology is constantly in flux, Contractor shall also research and propose designs to address these changing technologies (e.g. conversion to digital signals).

Please Note: Smart classroom design(s) must contain the following capabilities and components. Only components from leading audio and video manufacturers should be recommended. This list may contain equipment that is not required as part of the Contractor's proposed system. If so, please make note of each equipment item and provide an explanation as why the item is not needed.

1. NEC Multimedia Projectors (other brand may be substituted with the Universities' approval).
 - a) Clarion - 3500 lumen (Minimum)
 - b) True XGA resolution (1024x768)
 - c) Minimum manufacturer's 3 year warranty available at no additional charge
2. Device switching will be accomplished by the use of an Extron MLS406 OR MLS406SA (DEPENDING ON UNIVERSITY DESIGN)Medialink switcher. User control of this switcher will be through the use of an Extron MLC 226 IP DV+ Medialink desktop control pad. IP-based network control will be configured to allow remote access and support capabilities. Audio will be provided by an Extron MPA 401-70V amplifier.
3. Smart Technologies 18" series 500 Smart Panel with adjustable stand -
4. Document Camera (other brand/model may be substituted with the Universities' approval).
 1. Option 1 – Samsung SDP-860
 2. Option 2 – Elmo P10
 3. Option 3 – Samsung SDP-900 DXA
5. Projector drop post ceiling mount for specified projector (includes Chief CMA-440, RPAU, and appropriate length CMS column). A finishing bushing/grommet/flange shall be placed around the pipe where it protrudes through the ceiling tile for aesthetic purposes. Drop-ceiling access is typically available for the mounting of projector and cabling.
6. Speakers with appropriate tile bridges or compatible (please specify make, model, size and wattage output) Current standard is Four ceiling mounted speakers – JBL Control 24CT
 1. Option 1 - Two wall mounted Atlas SM52TB or JBL Control 28
7. DVD/Blu-ray unit (please specify make and model)
 1. Option 1 - DVD/VCR Combo player
 2. Option 2 – DVD/Blu-ray player
8. DaLite Model C wall/ceiling screen package with Controlled Screen Return and all necessary mounting hardware (if other, please specify make and model). Other screen models/sizes may be needed based upon site visit.
 - a) Standard-Specify screens in (8', and 10') widths and 4:3 and 16:9 ratios
 - b) Anti-keystone adjustable wall brackets
 - c) Matte White
 Recessed and electrically operated screens may be specified for specific installs

9. Media Teaching Podiums - Alternate podiums may be proposed in addition to those identified below (based on approval)
- a) Standard Podiums:
 - i. Model A –RWH MP-36T Clarion Podium
 - i. RWH Products, LLC
11994 Summit School Road
Huntingdon, PA 16652
Phone: 814.667.3101
Fax: 814.667.3102
 - 1. The podium must have locking doors and sufficient space to house all the necessary A/V components including an audio amplifier, DVD/Blu-ray Player, and Windows mid-tower PC. Podium shall have lockable casters and allow the unit to be mobile. Controller must be located on the podium. An Extron Cable Cubby 200 will be installed on the podium dash panel with laptop (Win or Mac) connections for video/audio, USB, power and network. Rack mount rails (and shelving if necessary) shall be included for mounting of switcher, DVD/Blu-ray, etc.
 - ii. EST # 1194 Mobile AV Cart/Desk
 - i. RWH Products, LLC
11994 Summit School Road
Huntingdon, PA 16652
Phone: 814.667.3101
Fax: 814.667.3102
 - 1. The podium must have locking doors and sufficient space to house all the necessary A/V components including an audio amplifier, DVD/Blu-ray Player, and Windows mid-tower PC. Podium shall have lockable casters and allow the unit to be mobile. Controller may be located on the podium or adjacent wall depending on particular room... Rack mount rails (and shelving if necessary) shall be included for mounting of switcher, DVD/Blu-ray, etc.
 - b) Additional Edinboro Options
 - i. Option 1 - Media Director Podium (Spectrum)
 - 55160IDTK Media Director Podium
 - 55164I "Mdp" Optional Folding Shelf
 - 55163 "Mdp" Optional Keyboard 10"
 - 55159D "Mdp" Optional Rack Rail Shelf
 - 99002 Power&Comm Module W/O Jack
10. Security devices are utilized to secure equipment and deter theft. The following specific components are used at each campus location.
- a) Clarion Installations
 - i. Computer Security Products CSP-780 security cables will be attached to equipment and projector. Locks on the cables shall be keyed alike to Clarion standard key #001. Additional XLK/U and PLT-591 will be ordered as if needed
 - b) Edinboro Installations
 - Secure-It Sonic SSA-100 for ceiling mounted projector
 - AB30KA 1.25 inch Padlock Keyed a like (3002) (qty 4)
 - HC44B 6 foot laminated Cable Black w/lock ends and keyhole washer (qty 4)
 - MC98 Micro slot clip (qty 5)
 - ML94 Standard Mouse Loop (qty3)

Classroom Specifications, Installation Guidelines, and Procedures

3.3 General Requirements:

- A. The Contractor shall carry all insurance required by the Pennsylvania State System of Higher Education and provide proof of such.
- B. The Contractor will have a primary design/sales consultant assigned to each university account. This representative will be responsible for scheduling, managing projects, providing preliminary system designs, product information, and pricing quotations. A lead installation technician will also be assigned who'll be responsible for scheduling system installations and completion of all work orders.
- C. Contractor will conduct quarterly review meetings to review past project performance, pricing validation, and discuss changes of technology.
- D. The Contractor shall provide project management for all installations which include, but not limited to the following:
 - 1. Project installation scheduling
 - 2. Daily / weekly status updates
 - 3. On-site review of quality and timeliness of installations
 - 4. Quarterly meetings to review efficiency factors
- E. Within 3 months of the contract signing, the Contractor (or Subcontractor), at their own expense, will train a second technician as a backup and will be familiar with work procedures, a/v system designs, and campus layout.
- F. The Contractor will follow all industry standard installation and design procedures for audio/video systems in addition to building code requirements.
- G. The Contractor shall provide diagnostic and support services on a variety of audio/video systems and equipment. Response time shall be next day service unless otherwise stated.
- H. Contractor will be required to perform a site evaluation for each classroom and then submit a design plan with scope of workhand wiring diagram (**in VISIO only**) for approval prior to installation.
- I. The Contractor, upon request, will provide product demos and cost estimates for A/V equipment and preliminary system designs at no cost.
- J. The technician will return all completed work orders at the end of each day. A record of labor hours, equipment used, and completion information will be provided to the University, for each installation project, within one week of the completion of that project. If a project consists of multiple rooms, then a completed work order for each room will be required.
- K. The Contractor shall provide system layout and design services for smart classrooms each of which consist of a multi-media projector, Symposium device, audio/video cabling, speakers, programmed control system, podium or cart, document camera (if applicable), installation of system, documentation, and user training. User training should include technical training for the university support staff.
- L. The Contractor shall provide their own tools, ladders, and diagnostic testing equipment sufficient to perform all related tasks required.
- M. The Contractor shall have at least one CTS certified or equivalent installer on site during any installation at the University. The Contractor will be expected to provide employees who are well trained in the field and have a minimum of 3 years of experience installing multi-media systems. ICIA Certified Technology Specialist (CTS) installers or other certified employees are preferred. (Certifications for employees must be included in response and must be updated if personnel change)
- N. The Contractor may utilize sub-contractors for the installation. However, all sub-contractors must be approved by the respective University and must meet the requirements listed within the RFP/contract.

The University reserves the right to reject any sub-contractor. Credentials must be submitted to university for approval and must be updated if personnel change.

- O. Additional services requested from the Contractor may include routine maintenance, audio/video calibration, and repair of audio/video equipment.
- P. In the event the Contractor is requested to repair or return a failed projector, controller, and/or switcher to the manufacturer under warranty, the Contractor shall provide a loaner for the defective unit until the repair is completed. (limited to three such units at anyone time)
- Q. Any audio/video equipment including multimedia projectors, controllers, and document cameras along with additional miscellaneous A/V components may be purchased through the Contractor. Contractor shall provide individual monthly invoices for each project per PO with an itemized list of equipment and services rendered for that project. All grants & discounts applied will be noted on the invoice. Pricing will be compared to the Department of General Service Contract,
- R. Emergency repairs will be done at the request of only the designated Clarion or Edinboro contact person(s). Upon notification, the Contractor will dispatch an available technician to the University. Emergency conditions are defined as those unscheduled services requested during hours not normally considered to be part of the usual 8:00AM-5:00PM work week.
- S. Periodically the Contractor will require the services of an additional helper(s). The helper's fee may be billed through the Contractor and the Contractor will be responsible for all payment to the helper plus any applicable insurance and/or compensation. This helper/sub-contractor should be aware and abide by the details outlined in this RFP and they should be aware and abide by any of the specific/unique policies and procedures each university requires of any vendor. The University holds no responsibility or liability for the Contractor's helper.
- T. The Contractor shall warrant all installations, workmanship, and provided materials/equipment to be free from defects for a period of one year (includes on-site service at no charge to the University). Contractor may also be requested to provide pricing to extend warranty period to three years (minimum) with on-site service.
- U. The University retains the right to elect to purchase audio/video equipment outside this contract.
- V. The Contractor shall complete an installation within 10 working days after commencement of the project. Within this timeframe all punch-list items, programming, and project sign-off will occur. The University retains the right to withhold 10% of the final invoice cost if this timeframe is not met.
- W. The Contractor shall provide, with equipment installations, an inventory of all installed equipment with serial numbers and all system/user manuals in electronic format, and, as-built diagrams in **VISIO file format** within 14 days of installation completion. The University retains the right to withhold 10% of the final invoice cost if this timeframe is not met.
- X. The Contractor shall deliver to the University, within 14 days of project completion, all other source code and documentation not specifically referenced elsewhere in this contract in its native digital file format(s) produced or modified in support of the contract. The University retains the right to withhold 10% of the final invoice cost if this timeframe is not met.
- Y. The Contractor must be an authorized Extron dealer and trained to make warranty repairs to installed systems. The Contractor shall also provide Extron/Crestron control as well as similar control system consultation, design, programming and/or debugging.
- Z. The University will not accept drop shipment of equipment. The contractor must make provisions for the delivery of all equipment, podiums, and related items at the time of installation. Special arrangements for a campus staging area may be considered if additional discounts or savings are identified.
- AA. Contractor will provide complete installation of all equipment, podium cabinet, Sympodium, computer (to be supplied by the University) along with loading of all necessary software as specified in the Scope of Work. Complete installation shall include the testing of all the components with a 100%

satisfactory result that meets the university’s need. Contractor shall submit an acceptance plan that demonstrates all components have been tested. Testing plan receipts will be part of final documentation

3.4 Cabling & Interface Panel:

- A. All cables shall be labeled at both ends with permanent laminated labels indicating origin, destination, and type of signal use.
- B. The contractor shall install only Plenum rated wire and cable inside building walls and ceilings. All cabling installed will be secured with “J” hooks above suspended ceiling.
- C. The contractor shall follow all applicable National Electrical Codes, State and County codes and local ordinances. It is the contractor’s responsibility to obtain the necessary permits.
- D. The contractor shall install plastic surface mounted raceway or wire mold which is permanently attached to walls and conforms to the following:
 - Edinboro Installations - When surface mounting cables, two 5 foot sections of Hubble Triple Track base (PB3BC5) with one PB3SC splice and one PB3IE internal elbow are typically required.
 - Clarion Installations –Hubbell PW2ABC7 raceway is typically used for surface mounting cabling.
- E. The contractor shall use the following wire, cable, electrical components and physical components or their electrical and physical equivalents.

The below table is a typical breakdown of cables used in a standard classroom. The contractor may propose alternate cables (based on approval).

Number of Cables	Contractor Part Number	Contractor Description	Suggested Contractor/ Manufacturer	Where to Install
1	VGA15P-P-50HRP	50' VGA plenum M-M cable	Comprehensive	For use inside walls or ceilings. One cable run from designated wall plate location to projector for VGA input.
1	PP-PP-CV-50HRP	50' plenum video cable	Comprehensive	For use inside walls or ceilings. One cable run from designated wall plate location to projector for composite video input.
1	DB9P-DB9J-50HRP	50' plenum serial cable	Comprehensive	For use inside walls or ceilings. One cable run from designated wall plate location to projector for RS 232 control
1	16-2C-TTP-BLK	Plenum speaker cable (1 pair 16 AWG)	Liberty	For use inside walls or ceilings. 1 pair of cables run from a designated wall plate location to designated speaker location
1	VGA15P-P-10HR	10' VGA M-M cable with 3.5mm audio	Comprehensive	For use with Cable Caddy in podium for laptop VGA connection
1	CAT5-350-10BLK	10' Cat 5e cable	Comprehensive	For use with Cable Cubby in podium for laptop network connection

1	USB2-AB-10	10' USBAB cable	Comprehensive	For use with Cable Cubby in podium for laptop USB connection
---	------------	-----------------	---------------	--

F. The contractor shall fashion/provide the following wall mounted interface plates:

Clarion/Edinboro Classroom Instructor Station Sample faceplate



(Extron MTP/HDMI UTAD Universal Transmitter part # 42-16602)

Plates shall be configured as shown above. For more information about the transmitter face plate see <http://www.extron.com/product/product.aspx?id=tphdutad&s=5>. As this face plate relies on the use of twisted pair cabling there is no corresponding face plate at the projector location. Instead there is the following receiver



(Extron MTP/HDMI Universal Twisted Pair Receiver part # 601048-01)

For more information about the receiver unit see <http://www.extron.com/product/product.aspx?id=mtphdmir&s=5>.

- G. Edinboro Conference Installations – Sample faceplate is listed below for a conference room scenario. The conference room scenario consists of a large screen display (LCD, Plasma or LED) with a hidden face plate behind the display and a source face plate located somewhere else in the room. These face plates have corresponding terminated connections.



The conference room face plate consists of the following:

Computer - One 15-pin RGBHV Female: from instructor station face plate to display face plate.

Computer Audio - One 3.5 mm Stereo Mini Jack: from instructor station face plate to display face plate.

HDMI– One HDMI female connection from instructor station face plate to display face plate.

Y-Pb-Pr- Three RCA for COMPONENT; red-green-blue: from instructor station face plate to display face plate.

SPEAKERS - Two RCA for left and right speakers: from instructor station face plate to display face plate.

Video - One RCA for video: from instructor station face plate to display face plate.

SPEAKERS - Two RCA for left and right speakers: from instructor station face plate to display face plate.

NOTE: All data network ports and electrical outlets are installed by Edinboro University.

3.5 Projector Terminations

The RGBHV coax will be terminated with a HD-15 D style VGA connector. The Video cables will be terminated with compression or soldered RCA connectors to match the video input connection on the data projector. The RS-232 control cable will be terminated with a DB9 D style connector along with the appropriate adaptor to connect to the control port of the projector. **At no time will screw type connectors be permitted.** The Contractor is encouraged to use pre-manufactured cables and wiring when practical. If cables are custom terminated, **each wire** shall be dressed with **clear heat shrink tubing**. The contractor shall not exceed the manufacturers maximum bend radius for any cable.

3.6 Internal lectern wiring and service connections to the wall plates

The presence of electrical tape is unacceptable in the finished assembly of the lectern or its umbilical cord.

All solder connections shall be dressed with clear heat shrink tubing

With respect to the lectern wiring and the Umbilical cord (the interconnect cable that connects the lectern to the building wiring), the contractor is urged to use the wire and cable specified in the accompanying list of materials. If the contractor chooses to make substitutions those items shall be electrically and physically equivalent.

The contractor shall provide a support structure for wiring harness inside the lectern cabinet.

The contractor shall use non plenum rated cable for point to point connections inside the lectern and in the construction of the umbilical cord.

The contractor shall use **pre-manufactured** VGA cables, VGA break out cables, Network cables, and USB cables in the assembly of each lectern.

The contractor will dress signal bearing wire or cable away from AC power cords.

All cables shall be labeled at both ends with permanent laminated labels indicating origin, destination, and type of signal use.

The contractor shall not over tighten nylon wire wrap used to secure wiring within the lectern cabinet. If nylon tie-wraps are used the seize tension of the tie-wrap shall be so great as to inhibit the tie-wrap from being rotated about the wire bundle that it secures.

The Umbilical cord shall be dressed through pre cut opening in the bottom or bottom side of the lectern cabinet. Additionally, the main power cord shall be dressed through the same opening.

The vender shall use "3M Dual Lock Fastening system" or its equivalent to affix all power supplies and other modules to the floor of the lectern. Velcro fastening systems consisting of felt are not acceptable.

All cables shall be installed within the lectern in a **neat and orderly manner** as to allow easy identification and traceability of each cable. At no time are cables to be randomly placed in the podium.

3.7 Cable Cubby:

The Cable Cubby shall be an Extron 200 series and will have three cables (VGA with audio, USB, and network) that can be pulled from the user compartment. The cable cubby shall provide for 110 vac for laptop power. The contractor shall ensure unrestricted return of these cables to the cubby compartment.

Rest of Page Intentionally Left Blank

3.8 Umbilical Cord Construction:

Umbilical cord construction shall consist of Expandable Braided Non Fraying Polyester sleeve Alpha GRP-110NF or equivalent. The finished length of the Umbilical Cord shall be 20 feet. The cord should be constructed such that it can easily and repeatedly coiled and uncoiled without kinking of the cabling inside of the expandable sleeve. The contractor shall not bundle by use of **electrical tape or tie-wrap**, along its length, any cable or wiring to be inside the expandable sleeve also known as the Umbilical cord.

Within the sleeve, the vender shall install the appropriate cables that are required for the project. A sample configuration is noted below:

1	Extron MHR VGA 25' cable (26-238-03) or its equivalent
1	Comprehensive 25' video cable (PP-PP-CV-25HR) or its equivalent
1	Comprehensive 25' serial cable (DB9P-DB9J-25) or its equivalent
2 (stereo signal)	Comprehensive 25' speaker cable (SPK-SPK-25 EXF) or its equivalent
2	Cat 6 Network Patch Cable, 25', Color: Blue, configured for 568A Termination
1	1/8' vinyl coated steel aircraft cable

After the above components have been pulled through the expandable sleeve, the sleeve shall be terminated as follows:

- Leave cable tails of about 12 inches for connection to the building and the connection plate inside the Link cabinet wall plates. Note: The network cable may be longer to reach its respective connection.
- The 1/8 inch steel cable should be about 6 inches long after it has been terminated with a thimble and Gripple
- Fold the end of the Expandable sleeve back into itself about nine inches. See figure 1. Secure with TY-Gripfastener or tie-wrap of adequate size. Insert a snap hook through the thimble eye.
- Remove the excess slack in the expandable sleeve. The sleeve should hug the internal cables within it.
- Connect one umbilical cable tether to the eyebolt in the wall using the snap hook and connect the opposing end to the eye bolt inside the lectern cabinet.
- All Umbilical cord cables shall have permanent, non-paper, printed labels designating the signal carried by the cable install on each end of the cable(s).
- All umbilicals shall include a 1/8' vinyl coated steel aircraft cable as a carrier. **At no time shall an umbilical depend on the signal cables to function as a carrier or strain relief.**

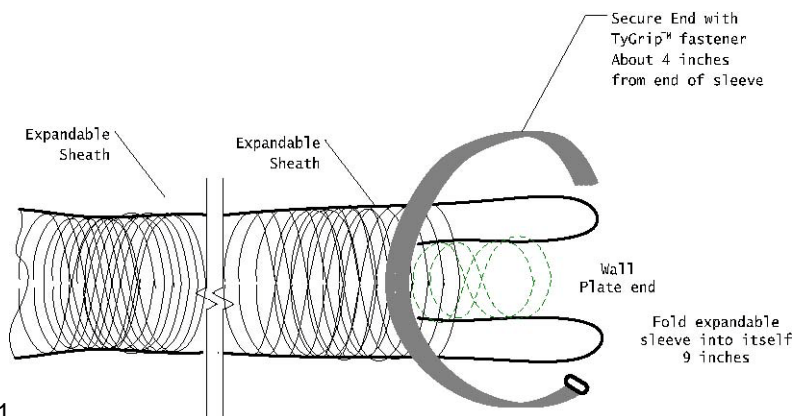

Figure 1

3.9 Projection System

Projector mounting systems shall be physically attached to the building via anchors driven into the cement or bolted/cabled to ceiling trusses, etc. **Free standing, drop ceiling components are not acceptable as fixed structures. Drop ceiling type mounts must be anchored at all 4 corners to the driven anchors or ceiling trusses. (Alternate projector mounting techniques will be approved only on an exception basis)**

The data projector should power up and down via a button presses from either the lectern desktop controller or the MLS406 OR MLS406SA (DEPENDING ON UNIVERSITY DESIGN) front panel.

The contractor shall ensure that all signals shall be free of geometric distortion including keystone issues, centering issues, focus issues, brightness & contrast issues and clock phase and timing issues.
The image shall not overshoot the projection screen nor encroach on the black trim area.

The projector should respond quickly to input changes via the lectern desktop controller and the MLS406 OR MLS406SA (DEPENDING ON UNIVERSITY DESIGN) front panel.

The RS-232 connection shall be tested by connecting a serial cable to the MLC 226 IP DV+ controller and successfully reading the projector statistics through the configuration program.

3.10 Audio/Video

Speaker type and quantity will depend on final room design

Option #1 (standard configuration) - A minimum of (4) JBL (or equivalent) ceiling speakers will be installed and attached to the MPA 401-70V using a 70 volt distributed output to provide audio from all components to the classroom (speaker quantity may change depending on room size and at the discretion of the University).

Option #2 - 2 JBL (or equivalent) wall mount speakers will be installed and attached to the MPA 401-70V using a 70 volt distributed output to provide audio from all components to the classroom (speaker quantity may change depending on room size and at the discretion of the University).

Any video/audio DAs shall be Extron manufactured unless otherwise approved by the University.

All system microphones shall be of adequate volume and free from sonic feedback.

The sound from these devices should be clear and free of clipping distortion. Acceptance is dependent on the successful demonstration of the aforementioned using a DVD disk and a VHS tape.

3.11 Device control

Device switching will be accomplished by the use of an Extron MLS406 (Clarion) OR MLS406SA (Edinboro) Medialink switcher. User control of this switcher will be through the use of an Extron MLC 226 IP DV+ Medialink desktop control pad.

Classroom System Capabilities shall include, but not be limited to the following:

Room controller package shall offer the following programmed buttons and be compatible with the installed projector. Controller must offer various mounting options. Control software shall be provided free of charge and offer a library of

software drivers for a variety of projectors. Controller shall offer a three year hardware/software warranty with free technical support.

- Buttons shall be programmed as in the following figure and shall include Projector On, Projector Off, A/V Mute, Lectern Computer, Laptop Computer, Document Camera, DVD, and VCR. If an electric screen is included, there shall also be buttons for screen up and screen down.
- Shall mimic the functions of the DVD/ VCR remote control including: Play, Stop, Skip forward, Skip backward, Fast forward, Fast reverse, Menu, Chapter/ Track selection, Enter, Pause, Channel selection etc.

The Desktop control pad:

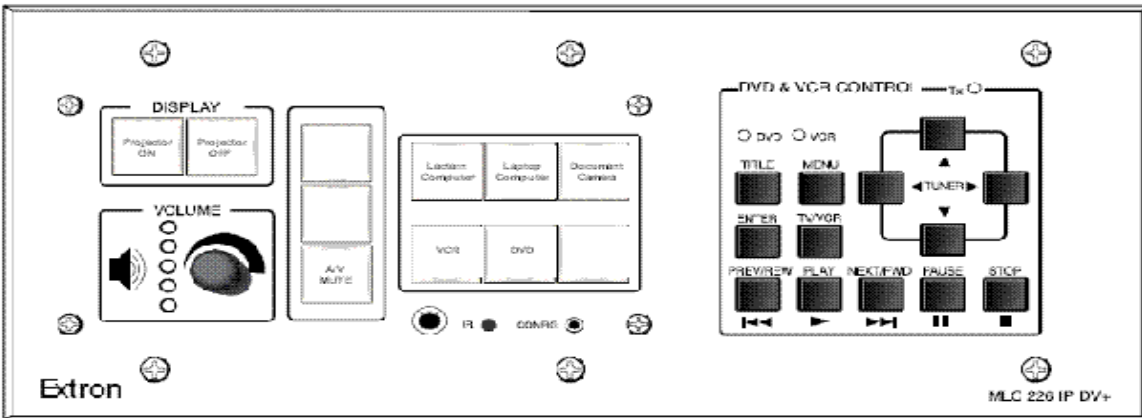

Extron
MLC 226 IP DV+

A network interface and web server option must be available which integrates directly with the proposed controller. The option must offer real-time control, status and usage information, e-mail alert or event triggers, and projector lamp metering. The switcher/control system will be set up for network asset management by the Contractor via a static IP address assigned by Computing Services networking staff.

3.11.1 Clarion Alternative System

Device switching will be accomplished by the use of an Extron Pole Vault System

3.12 Guest Laptop and local CPU

A laptop computer shall be connected to the desktop guest VGA, Audio and Network cables emanating from the cubby. The Ethernet cable, Audio cable, both USB ports and the AC power outlet are part of the acceptance test. The laptop desktop image should be un-cropped, clear and the output audio should be clear and free of clipping distortion when playing through the speaker system.

As part of the acceptance test the lectern CPU will be activated; the network should be accessible. Additionally, its desktop should appear un-cropped and properly centered on the viewing screen. Sound from this device should be clear and undistorted when played through the sound system. The desktop USB ports must be functional. A USB device shall be inserted into each desktop USB port that device should be recognized by the lectern CPU.

3.13 Documentation:

The contractor will supply all user manuals on CD's containing PDF files for all the equipment in the classroom

installation, projector, lectern, etc.

The contractor will supply on CD all IR and serial drivers, protocols, software, access codes, source & object code used in the install.

The contractor will supply an AS built on CD of the entire project including a parts list, full schematics (in Visio format), connector pin-outs and related drawings along with an inventory of all installed equipment with serial numbers,

All documentation shall be delivered to Clarion or Edinboro University's Media Technology Specialist within 14 days of project completion

3.14 Special Provisions:

All unused space in the 19" equipment rack must be filled with blank, black filler panels.

Without exception, any and all program source and compiled code generated to control any part of the audiovisual system provided in this project is the sole property of the requesting University. This includes but is not limited to programming for AMX, Crestron or Extron Control Systems and DSP programming for Clear One, BiAmp, Polycom, and other such products and the University(ies) further reserve(s) the right to use or modify the source and compiled code to facilitate system upgrades or use in another system".

A system manual shall be developed that includes all user operating documentation along with a design a schematic in VISIO format that identifies components & the system configuration.

Mounting equipment shall include the necessary labor and cabling for all equipment sources, distribution amplifiers, and projector "drop post" mounting hardware for attaching projector to the building structure.

A training session covering all system capabilities (1 hour minimum) shall be scheduled in advance after system is installed and fully operational.

All equipment shall be new and shall carry a one year on-site warranty with next day response provided through the installing dealer (three year minimum warranty upgrade option shall be provided). This warranty shall be executed by a single phone call to the installing dealer who'll then be responsible for the diagnosis and repair of all problems. A next day loaner service shall be provided for the following critical components (system switcher, controller, and multi-media projector). The system warranty will also include one annual preventive maintenance visit to clean and recalibrate any system components.

Installation of systems shall be by a certified Audio/Visual integrator and offer a complete turnkey solution. The installer shall be responsible for providing all components, wiring, and services necessary to implement an operational system as per stated requirements and attached equipment specifications. All equipment shall be delivered at the time of installation (an approved schedule will be established). The University will not accept any equipment related to the installation that is either sent or drop shipped unless prearrangements have been approved by the university.

3.15 Acceptance Testing

Acceptance testing shall be based on the adherence of the aforementioned specifications and contractor craftsmanship.

- The lecterns when assembled shall be free of construction dust and debris. All visible surfaces shall be clean and free of oils and other manufacturing compounds.
- All indicator lamps must be working.
- All panels should be in place.
- The Belkin USB switch (if used) will be checked for proper operation and that the resident PC will be designated as the default

- All specified cable designation labels and engraved/silk screened markings (on the contractor installed wall plates) should be clearly visible.
- All connections including the VGA, video, audio, network cables and tether cable should be in place.
- All ceiling tiles should be in place and free of construction damage. The contractor shall certify that all ceiling speakers are installed so as to ensure no collapse or bowing of the ceiling tiles.
- The contractor will certify that the all the contractor supplied network components/connections are functioning @ minimum CAT 5E specification.
- The contractor will certify that the sound is evenly distributed by injecting a 1 kHz test tone signal operating into the system amplifier and measure the SPL in db throughout the room. SPL levels shall not vary more than 2 db from speaker to speaker. All speakers should reproduce sound of equal timbre and produce undistorted sound. All system microphones shall be of adequate volume and free from sonic feedback.
- All functions, including programming, shall be tested for proper operation and witnessed by the University designee before acceptance is granted.

Rest of Page Intentionally Left Blank

Sample Design Diagram

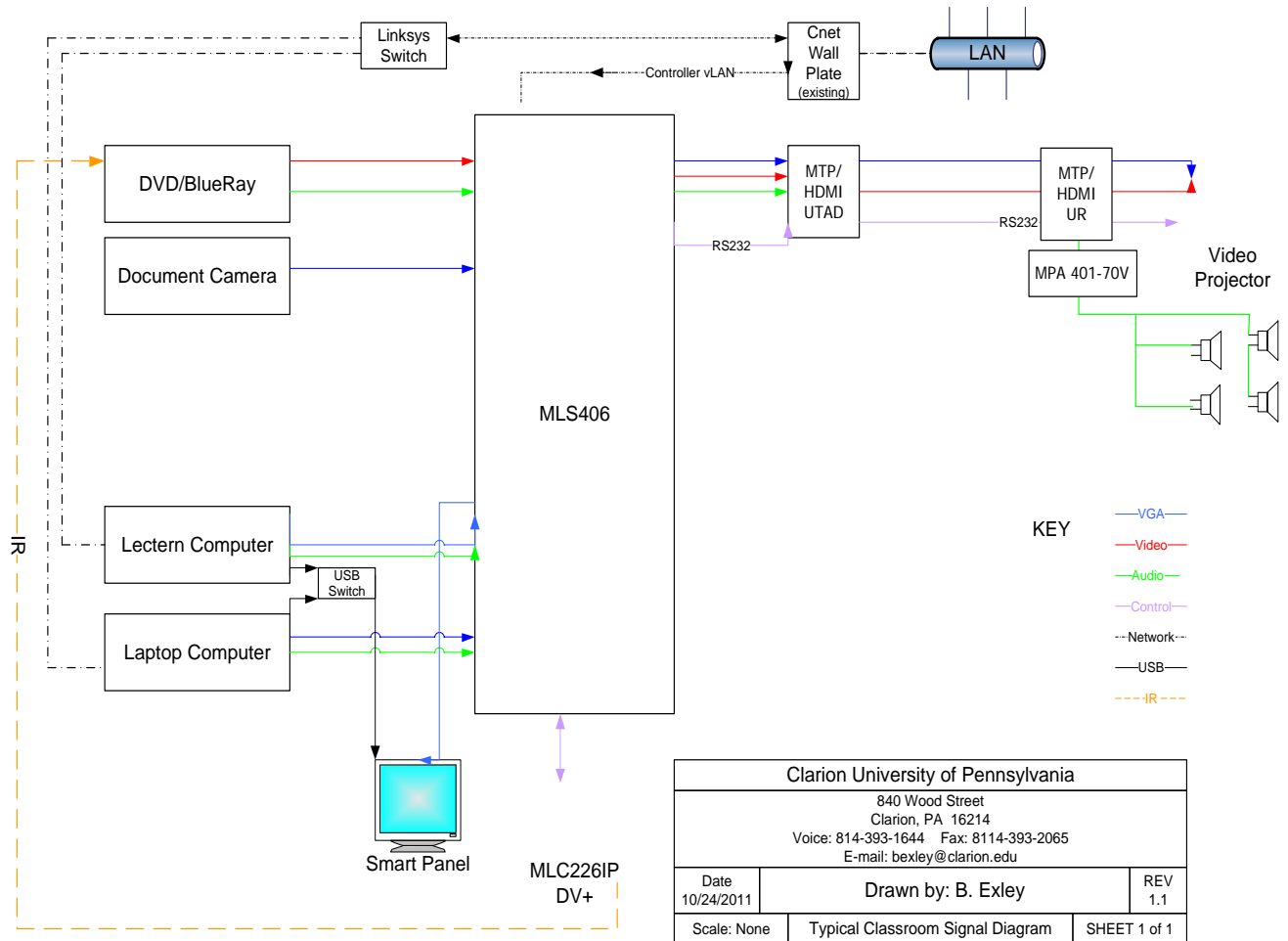

4.0 Clarion University Venango Campus Nursing Simulation Lab

Vendor shall be prepared to provide design, equipment, and installation of a 2 bed nursing simulation lab, associated control room, and debriefing/conference classroom to be located in Montgomery Hall at Clarion's Venango Campus.

A. Nursing Skills/Physical Assessment Bed Areas (2 locations) Description:

The Nursing Skills/Physical Assessment bed areas allow students to practice and hone their skills prior to client/patient contact and replicate the traditional patient/exam rooms that students are likely to find in both their clinical placement experience and in their future practice as nurses.

Integration with existing equipment:

(3) Simulation manikins will be interfaced with the lab. All operation and functions of the manikins will be controlled by the existing wireless (with the option for wired) laptop computer -Macintosh.

The type and manufacturer are as follows:

- 1.) METI iStan adult simulation manikin
- 2.) METI Baby SIM
- 3.) Gaumard NOELLE Birthing Simulation Manikin

Room Requirements must include for *each bed area* (but not limited to) - see drawing for layout details:

- 1.) 2 - Ceiling mounted pan/tilt/zoom color cameras, 1 each located at head and foot area of bed, to provide remote video monitoring/recording of nursing students during simulations.
- 2.) 2 - Ceiling mounted microphones (Audio Technica Part # ES945W or equivalent) to provide for audio monitoring/recording of student conversations during simulations.
- 3.) Ceiling speakers to provide simulation ambient noise as well as voicing of simulated patient vocal responses and feedback communication from instructors. (quantity to be proposed)
- 4.) 1 – 32" LCD screen to provide display of simulated EKG/Vital signs and statistical information.

B. Control Room Description:

Located next to the Nursing Skills/Physical Assessment bed areas is the Control Room which houses the technology used to create and run simulations. Additionally, this room is equipped with one-way glass which allows faculty to observe students as they participate in the simulation without the students seeing and being distracted by their presence. The audio and video of each scenario is to be recorded digitally to allow students and instructors an opportunity to playback and discuss the training event during the debriefing session. The Control Room allows instructors to interact with the students and control the manikins from a central location.

Control Room Requirements must include (but not limited to) - see drawing for layout details:

- 1.) Full remote control of all PTZ cameras
- 2.) Ability to inject simulation ambient noise as well as voicing of simulated patient vocal responses and feedback communication from instructors to ceiling speakers located in bed areas (includes all amplifiers and controls needed)
- 3.) Ability to provide feeds of simulated EKG/Vital signs, scenarios, and statistical information to LCD monitors in bed areas. Including integration and synchronization of simulation recording with patient simulation logs and patient monitor to provide a complete session record
- 4.) Full support for real-time (30 fps) video and audio streams.
- 5.) Network based ability to multi channel record all audio, video, and computer data used in simulations from either or both (simultaneously) via NVR (network video recorder).
- 6.) Storage capacity of NVR shall be such to accommodate (minimum - 8TB HD online recorded sessions) with DVD burning capability to archive (optionally a separate unit)
- 7.) Separate automated switching control for easy operation of the two assessment rooms
- 8.) Ability to forward any audio/video feed or recording to the instructor's podium in the conference room for remote viewing/debriefing/instruction.
- 9.) Provide for any needed interaction capabilities with simulation manikins
- 10.) Video/audio source/destination selections should be provided by a multichannel (e.g. matrix) AV switching system with touch screen control.
- 11.) Provide two (2hr minimum) user training sessions with operational manual
- 12.) Provide all components, cabling, and interconnection in order to install a fully operational system

C. Conference/Debriefing Room

The Debriefing Room provides a space where students can come together with their faculty instructor after running a simulation or to observe their colleagues in simulation. This space includes traditional teaching materials such as a projector, a white board, and tables with chairs to facilitate dialogue and collective analysis. **The Conference/Debriefing Room will include (at minimum):**

- 1.) A full "Smart classroom" based on standard CUP design listed above in **section 3.2** which would include:
 - A Teachers podium
 - Extron Control System
 - Ceiling mounted multimedia video projector with recessed projection screen
 - DVD/VCR combo
 - Document camera
 - Inputs for Resident PC and laptop computers
 - Audio system with ceiling speakers
 - A podium gooseneck microphone and wireless lapel microphone system
 - Ability to accept and project input from the Sim Lab control room
 - DaLite CSR recessed screen with box for integrated ceiling installation (size to be determined).
Box will be provided to project General contractor for pre-install with suspended ceiling grid work. Smart Classroom/AV Contractor will install mechanism/fabric.

This project MUST allow for future expansion/updates and inclusion of additional manikins (may be of different manufacture).

Rest of Page Intentionally Left Blank

Clarion University Venango Campus Nursing Simulation Lab Layout

Sheet 1

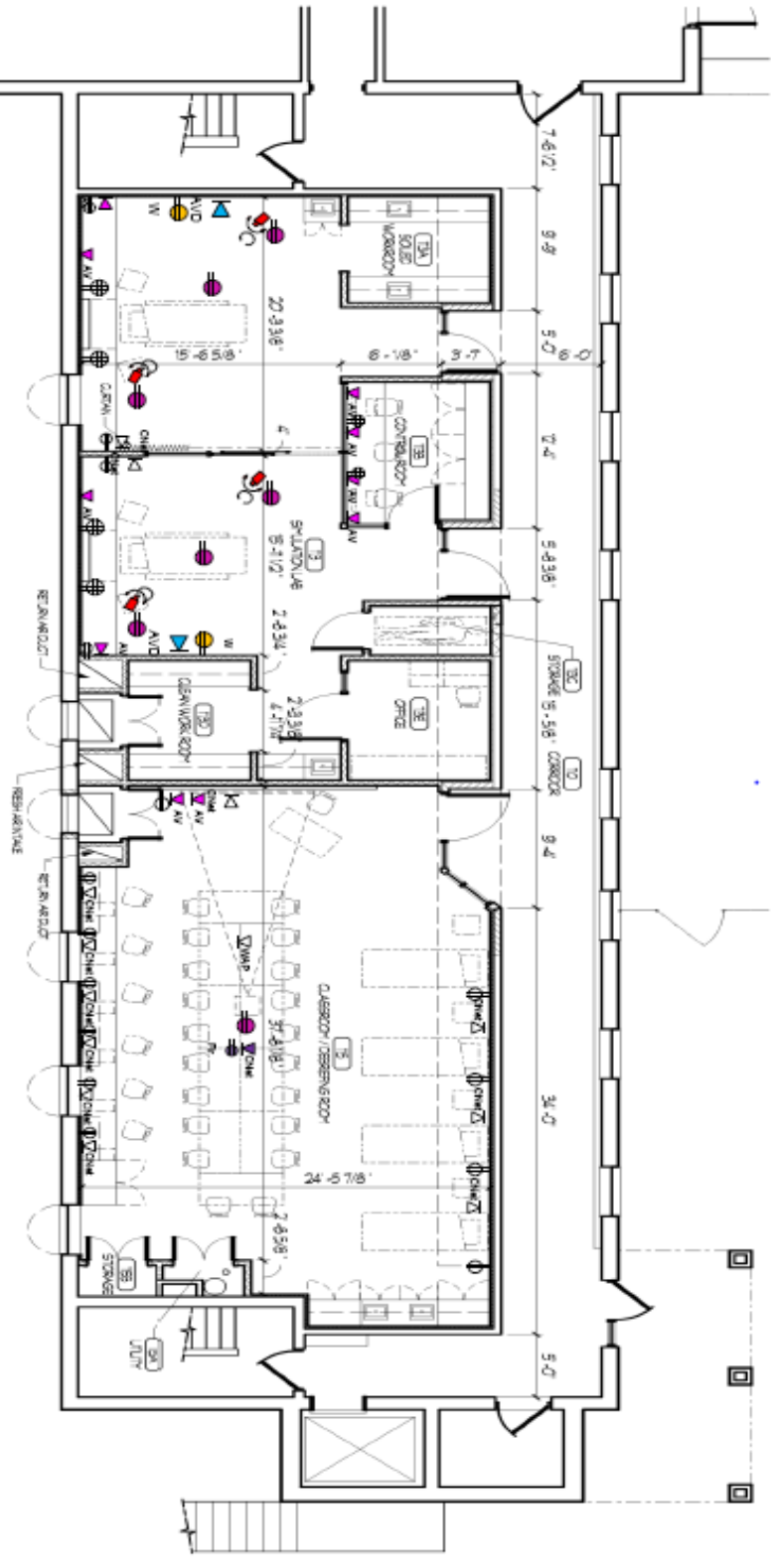

-  Double gang recessed box (1) 1/2" conduit stubbed to above ceiling - 8" below finished ceiling
-  Triple gang recessed box with 2 gang mud ring 2 1/2" conduits stubbed to above ceiling
-  Ceiling Mounted PTZ camera
-  120vac Hubbelle surge outlet above ceiling for video projector
-  120vac Hubbelle surge/wall outlet 8" below finished ceiling

4.0 ATTACHMENTS

The following attachments include:

ATTACHMENT A – Bid Proposal Form / Contractor Qualification Statement

ATTACHMENT B – Sample of Commonwealth/University Contract

Rest of Page Intentionally Left Blank

CLARION UNIVERSITY OF PENNSYLVANIA
STATE SYSTEM OF HIGHER EDUCATION

EDINBORO UNIVERSITY OF PENNSYLVANIA
STATE SYSTEM OF HIGHER EDUCATION

**Multi-Media Classroom System and
A/V Equipment/Installation Pricing**

BID PROPOSAL

Proposal of: _____
(Name) (Federal ID #)

_____ (Address) _____ (Business Telephone)

Hereinafter called "Bidder".

To: Clarion University of Pennsylvania, hereinafter called "University".

Sirs:

In conformity with your invitation for bids on Multi-Media Classroom System and A/V Equipment/Installation Pricing, and having examined the Specifications and Conditions and being familiar with all conditions in connection with the proposed project, the Bidder does hereby propose to furnish all services in accordance with the Bid Documents at a price stated hereinafter.

The undersigned agrees that he will not withdraw his bid for a period of sixty (60) days from the date of bid opening.

The Bidder understands that the University reserves the right to reject any or all bids and to waive any informalities in the bidding.

Upon receipt of written notice of acceptance of this bid, the bidder will execute and deliver certificates of insurance within ten days or as required.

Pricing Section

Standard Classroom Pricing Schedule

- Contractor must identify any special grants pricing (i.e. SMARTer Kids grant, promotional discounts, etc).
- If additional discounts are available beyond the listed quantities below, please provide target levels.
- Technology components may be modified at any time to better align with the changing instructional needs.
- The below configuration may be modified to accommodate variations in technology capabilities.

Number	Item	Clarion Single Installation	Clarion 3 or More Installations	Edinbore Single Installation	Edinboro 3 or More Installations
1	RWH CUSTOM PODIUM - Model A – RWH MP-36T Clarion				
2	18" SMART TECHNOLOGIES SERIES 500 SMART PANEL - SP518-NB				
3	EXTRON 70 VOLT POWER AMPLIFIER - 60-845-01				
4	EXTRON FLEXIBLE CONDUIT ADAPTER KIT - 70-228-02				
5	EXTRON MLC226 MEDIALINK CONTROLLER - MLC226IP DV+				
6	EXTRON MLS406 (CLARION UNIVERSITY)				
	EXTRON MLS406SA (EDINBORO UNIVERSITY)				
	(Option 1)EXTRON MPS409				
7	EXTRON MTP/HDMI UR UNIVERSAL RECEIVER - 60-1048-01				
8	EXTRON MTP/HDMI UTAD UNIVERSAL TRANSMITTER - 42-166-02				
9	EXTRON PMK-350 POLE MOUNT ACCESSORY TRAY - 70-563-03				
10	EXTRON PS-124 POWER SUPPLY - 60-1022-01				

11	EXTRON CABLE CUBBY 200				
12	NEC PROJECTOR - 3500 ANSI LUMENS OR HIGHER				
13	DVD/VCR COMBO PLAYER				
	(Option 1) BLUERAY PLAYER				
14	(4) JBL CEILING SPEAKERS - Control 24CT (or equivalent)				
	(Option 1) (2) JBL WALL SPEAKERS - Control 24CT (or equivalent)				
15	CHIEF UNIVERSAL LCD PROJECTOR MOUNT - RPA-U				
16	CHIEF UNIVERSAL LCD PROJECTOR MOUNT CEILING PLATE - CMA-440				
17	CHIEF EXTENSION COLUMN PIPE				
18	(Option 1) SAMSUNG DOCUMENT CAMERA - SDP-860				
	(Option 2) ELMO DOCUMENT CAMERA - P-10				
	(Option 3) SAMSUNG DOCUMENT CAMERA - SDP-900 DXA				
19	GYRATION WIRELESS MOUSE/KEYBOARD SUITE - GYM1100FKNA				
	(Option 1) GYRATION AIR MOUSE ELITE - GYM5600NA				
20	DA-LITE MODEL C 8' x 8' MANUAL WALL SCREEN w/CSR				
	(Option 1) DA-LITE MODEL C 10' x 10' MANUAL WALL SCREEN w/CSR				
	(Option 2) DA-LITE MODEL C 69" x 110" 16:10 MANUAL WALL SCREEN w/CSR				
	(Option 3) DA-LITE MODEL C 87" x 139" 16:10 MANUAL WALL SCREEN w/CSR				

21	DA-LITE 40932 WALL BRACKETS FOR MOUNTING SCREEN -				
22	MIDDLE ATLANTIC PD915R POWER STRIP				
23	MIDDLE ATLANTIC U2 RACK SHELF				
	(Option 1) MIDDLE ATLANTIC U3 RACK SHELF				
24	COMPUTER SECURITY PRODUCTS CSP-780 SECURITY CABLE – KEY #001 (Clarion Option)				
	Security cables - Computer Security - Secure-It Sonic SSA-100 - AB30KA 1.25 inch Padlock Keyed a like (3002) (qty 4) - HC44B 6 foot laminated Cable Black w/lock ends and keyhole washer (qty 4) - MC98 Micro slot clip (qty 5) - ML94 Standard Mouse Loop (qty 3) (Edinboro Option)				
25	Kramer SVGA Splitter 1 x 2 - VP200N (Edinboro Option)				
26	BELKIN F1U201v 2 x 1 USB SWITCH				
Total shipping / delivery costs for all equipment (if applicable)					
<u>Complete installation for a fully operational system</u>					
	Total Cost of Classroom System w/ one year onsite warranty (default options)	\$	\$	\$	\$
	Total Cost of Classroom System w/ three year on-site warranty (default options)	\$	\$	\$	\$
	Provide a clear and detailed explanation of any services and their value that Clarion and Edinboro can expect to receive with the eventual agreement resulting from this procurement				

Above total costs are final and must include any associated travel costs or shipping

Note: The University will not accept drop shipment of equipment. The contractor must make provisions for the delivery of all equipment, podiums, and related items at the time of installation. Special arrangements for a campus staging area may be considered if additional discounts or savings are identified.

Alternate Classroom (Extron PoleVault) Pricing Schedule

The following system is designated for limited space areas such as labs, conference and resource rooms, etc. where the normal standard is not feasible.

- Contractor must identify any special grants pricing (i.e. SMARTer Kids grant, promotional discounts, etc.).
- If additional discounts are available beyond the listed quantities below, please provide target levels.
- Technology components may be modified at any time to better align with the changing instructional needs.
- The below configuration may be modified to accommodate variations in technology capabilities.
- MULTIPLE CAT5 UMBILICAL SHALL RUN FROM LECTERN TO 6 – 8 PORT WALL PLATE

Number	Item	Model	Single Installation	3 or more Installations
1	RWH CUSTOM PODIUM	EST # 1194 Mobil AV Cart/Desk		
2	18" SMART TECHNOLOGIES SERIES 500 SMART PANEL (REPLACES MONITOR)	SP518-NB		
3	FIVE INPUT TWISTED PAIR POLEVAULT SWITCHER WITH INTEGRATED 50 WATT STEREO AUDIO AMPLIFIER	PVS 305SA		
4	VIDEO 3' COMPOSITE OUT TO PROJECTOR CABLE	V RCA/3		
5	MALE TO MALE MICRO VGA CABLE	MVGA M-M/3		
6	TWO INPUT VGA AND STEREO AUDIO SWITCHER	PVT SW RGB		
7	CAT5 RJ-45 MALE TO MALE - PLENUM: 50' (15.2M) (QTY OF 4)	UTP23-4/50		
8	COMPOSITE VIDEO UTP TRANSMITTER (QTY OF 2)	PVT CV		
9	MEDIALINK® CONTROLLER WITH IP LINK®	MLC 104 IP Plus		
0	TWO-GANG EXTERNAL WALL BOX: WHITE	EWB 102		
10	POWER, SWITCHER COMMUNICATIONS AND MPA VOLUME CONTROL CABLE - PLENUM: 50' (15.2 M)	MLC PW/RS-232/VC-50'		
11	PROJECTOR COMMUNICATION CABLE - PLENUM: 50' (15.2 M)	MLC IR/RS-232-50'		
12	NEC PROJECTOR - 3500 ANSI LUMENS OR HIGHER	NP-P350X		

13	FULL-RANGE CEILING SPEAKERS WITH 4" LOW PROFILE BACK CAN (QTY OF 4)	SI 3C LP		
14	PRE-CUT SPEAKER CABLE: 35' (10.6 M) (QTY OF 4)	SPK 18 cable-35'		
15	PROJECTOR DROP CEILING MOUNT WITH ADJUSTABLE POLE	PCM 340		
16	UNIVERSAL PROJECTOR MOUNTING BRACKET: WHITE	UPB 25		
17	POLEVAULT POLE MOUNT KIT	PMK 550		
18	SAMSUNG DOCUMENT CAMERA	SDP-860		
19	DVD/VCR COMBO PLAYER			
	(Option 1) BLUERAY PLAYER			
20	GYRATION WIRELESS MOUSE/KEYBOARD SUITE - GYM1100FKNA			
21	DA-LITE MODEL C 84IN X 84IN MANUAL WALL SCREEN	79860		
22	DA-LITE WALL BRACKETS FOR MOUNTING SCREEN	40932		
23	MIDDLE ATLANTIC PD915R POWER STRIP	PD915R		
24	MIDDLE ATLANTIC U2 RACK SHELF - Qty of 3	U2		
25	COMPUTER SECURITY PRODUCTS SECURITY CABLE – CLARION KEY #001	CSP-780		
26	BELKIN 2 x 1 USB SWITCH	F1U201v		
	MISC. CABLES, RACEWAY, ETC.			
	MULTIPLE CAT5 UMBILICAL SHALL RUN FROM LECTERN TO 6 – 8 PORT WALL PLATE			
Total shipping / delivery costs for all equipment (if applicable)				

<u>Complete installation for a fully operational system</u>			
	Total Cost of Classroom System w/ one year onsite warranty (default options)	\$	\$
	Total Cost of Classroom System w/ three year on-site warranty (default options)	\$	\$
Provide a clear and detailed explanation of any services and their value that Clarion and Edinboro can expect to receive with the eventual agreement resulting from this procurement			

Note: Pole Vault system installations shall conform to all requirements as listed above, including:

- 24x7 technical telephone support for Extron and NEC projector
- Projector warranty service shall include one year on-site warranty with next day response provided through the installing dealer. Including a replacement projector shipped by contractor within one business day with the original projector repaired and returned within five business days during the warranty period.
- Contractor will be responsible for any and all shipping and delivery costs.
- A training session covering all system capabilities (1 hour minimum) shall be scheduled in advance after the system is installed and fully operational
- Pricing must include any and all discounts applicable to the listed equipment (i.e. Grants, promotional discounts, etc.) and list all educational discounts.

Above total costs are final and must include any associated travel costs or shipping

Note: The University will not accept drop shipment of equipment. The contractor must make provisions for the delivery of all equipment, podiums, and related items at the time of installation. Special arrangements for a campus staging area may be considered if additional discounts or savings are identified.

Additional A/V Equipment

Edinboro Alternative Podium/Lectern

Media Director Podium (Spectrum)	Edinboro Single Installation	Edinboro 3 or More Installations
55160IDTK Media Director Podium 55164I "Mdp" Optional Folding Shelf 55163 "Mdp" Optional Keyboard 10" 55159D "Mdp" Optional Rack Rail Shelf 99002 Power & Comm Module W/O Jack	\$	\$
Shipping / delivery costs	\$	\$

Projector Specifications

Projectors shall support native XGA resolution (1024x768 minimum), have zoom lens, and at a minimum, the following inputs:

RGB1(analog)	VGA 15-pin D-sub
RGB2(analog)	VGA 15-pin D-sub
RGB3(digital)	HDMI
Video 1	RCA
Video 2	S-Video
Audio 1	1/8 in. stereo
Monitor out	VGA 15-pin D-sub
Audio out	Yes (variable)

All projectors shall carry a three year (minimum) replacement warranty through the manufacturer with loaner service through the contractor/vendor.

Pricing Schedule: Enter unit pricing and model information for projectors with specified ratings.

Projector MFG/Model	3500 +/- Lumen Rating	4000 +/- Lumen Rating	6000 +/- Lumen Rating
Alternate 1			
Alternate 2	\$	\$	\$
Shipping / delivery costs	\$	\$	\$

Digital Visual Presenter Specifications

Presenters shall support native XGA resolution, (1024x768), 850,000 (minimum) pixels. A three year (minimum) parts and labor warranty with loaner service (if available) shall be offered through the manufacturer.

Pricing Schedule: Enter unit pricing for listed presenters.

Digital Presenter	Unit Price	Digital Presenter	Unit Price
Elmo P-10	\$	Samsung SDP-950DX	\$
Samsung SDP-860	\$	Alternative #1	\$
Alternative #2	\$	Shipping / delivery costs	\$

New Technology Pricing / Equipment Substitutions / Discount Structure

As technology changes over the life of this contract, the contractor shall provide consistent pricing discounts to new products and expanded A/V product offerings (i.e. Plasma/LCD displays, rear projection). The contractor is expected to maintain competitive awareness and provide new pricing structures as opportunities arise with additional discounts. Pricing and discount levels will be reviewed quarterly to ensure they are consistent and aggressive in comparison with other pricing within the educational market place.

Hourly Pricing Schedule

The Contractor shall propose labor costs to perform equipment installation, programming, and onsite repair services in accordance with this RFP. A brief description of the type of services included shall be provided. Overtime and Holiday rates and respective timeframes when applicable shall be identified. Any increases for labor shall follow the standard CPI rate structure.

	<u>Regular Rate</u>	<u>Overtime Rate</u>	<u>Holiday Rate</u>
<u>Indicate the rate you wish to charge per hour for each installer on-site</u>			
<u>Equipment & cabling Installation</u>	\$ /Hr	\$ /Hr	\$ /Hr
Description of Services:			
<u>Additional Helper for Installation</u>	\$ /Hr	\$ /Hr	\$ /Hr
Description of Services:			
<u>Onsite General Support and Diagnostic Services (non-warranty systems or equipment)</u>	\$ /Hr	\$ /Hr	\$ /Hr
Description of Services:			
<u>Extron/Crestron Controls Programming</u>	\$ /Hr	\$ /Hr	\$ /Hr
Description of Services:			
<u>Travel costs if applicable</u>	\$ /Hr	\$ /Hr	\$ /Hr
Description of when travel costs apply			

Venango Simulation Lab Pricing Schedule

The Contractor shall propose costs to perform equipment installation, programming, and user training in accordance with section 4.0 for the Venango Campus Nursing Simulation Lab. A complete system design approach with a detailed description of integration/ installation services, and supplied components much accompany the pricing below.

Simulation lab system / price for assessment bed area and control room	\$
Simulation lab system / price for conference/debriefing room	\$

PART B - CONTRACTOR'S QUALIFICATION STATEMENT

(Complete only if you last completed a statement for Clarion University more than 1 year ago.
If statement was completed less than 1 year ago, give bid number last statement was completed for: _____.

The undersigned certifies under oath the truth and correctness of all statements and all answers to questions made hereinafter.

Submitted to: Clarion University of Pennsylvania
Room 210 Carrier Hall
Clarion, PA 16214 (Check one) (Check one, if applicable)

Submitted by: Name: _____ () Corporation () BBE
Enterprise) () Partnership (Black Business

Address: _____ () Individual () JMBE
_____ () Joint Venture (Minority Business Enterprise)
_____ () Other

Principal Office: _____ () PIBH
(PA Industries for the Blind/Handicapped)

1. How many years has your organization been in business as a provider of these services? _____ () WBE
(Women-Owned Business)

2. How many years has your organization been in business under its present business name? _____

3. If a corporation, answer the following:
Date of incorporation: _____
State of incorporation: _____
President: _____
Vice President(s): _____
Secretary: _____
Treasurer: _____

4. If a partnership, answer the following:
Date of organization: _____
Type of partnership: _____ (i.e. general, limited)

Name and address of all partners:

4. If other than a corporation or partnership, describe organization and name principals:

5. Does your firm have minority certification? _____ If so, please indicate certification number and classification: _____

6. Have you ever failed to complete any work awarded to you? If so, indicate when, where, and why: _____

7. Has any officer or partner of your organization ever been an officer or partner of another organization that failed to complete a contract? _____ If so, state circumstances: _____

8. List major contracts for similar type services your organization has in progress on this date.

<u>NAME</u>	<u>ADDRESS</u>	<u>PHONE</u>
_____	_____	_____
_____	_____	_____
_____	_____	_____
_____	_____	_____

9. List major contracts for similar type work your organization has had in the last five years.

<u>NAME</u>	<u>ADDRESS</u>	<u>PHONE</u>
_____	_____	_____
_____	_____	_____
_____	_____	_____
_____	_____	_____

10. Indicate name, address and telephone of agent that will be handling your insurance for this project: _____

If you are low bidder for this contract, you may be asked to submit a statement of financial conditions, including contractor's latest regular dated financial statement or balance sheet, which must contain current assets and liabilities. Are you willing to submit this information? _____

PROPOSAL SIGNATURE PAGE

When the bidder is an **individual**:

(Signature)

Witness:

(Date)

When the bidder is a **partnership**:

(Partnership Name)

(Partner)

(Partner)

(PARTNERSHIP SEAL)

(Partner)

(Witness)

(Date)

When the bidder is a **corporation**:

(Corporation Name)

(President)

(CORPORATE SEAL)

(Date)

ATTEST:

(Secretary/Treasurer)

The _____ is a corporation organized and existing under the laws of _____ and has (has not) been granted certificate of authority to do business in Pennsylvania as required by the business corporation law, approved May 5, 1933, P.L. 364, as amended.

The _____ is an individual or partnership trading under a fictitious or assumed name and has (has not) registered under the Fictitious Name Act of Pennsylvania; namely, the Act of May 24, 1945, P.L. 967.

CLARION UNIVERSITY OF PENNSYLVANIA

COMMONWEALTH OF PENNSYLVANIA
STATE SYSTEM OF HIGHER EDUCATION

CONTRACT
for
SAMPLE

Contract Inquiry No. **C (SAMPLE)**

THIS AGREEMENT, made and entered into this _____ day of _____,
between Clarion University of Pennsylvania of the State System of Higher Education, 840 Wood St.,
Clarion, PA 16214, (hereinafter "University," "Commonwealth," or "Agency"),

and

(Contractor's full name which must be in its legally recognized form, i.e., corporate registration, full legal name if an individual and must be the same throughout this Contract. Deviations must be satisfactorily explained, except that the Contractor may be referred to as "Contractor" within this document from this point forward) at (address) acting through its proper officials, (hereinafter referred to as "Contractor") (Federal I.D. # _____ or if an individual, Social Security Number).

Both the University and Contractor, when used together, are hereinafter referred to as Parties. The University is an instrumentality of the Commonwealth of Pennsylvania, established by and existing pursuant to Article XX-A of the Public School Code of 1949, as amended, 24 P.S. § 20-2001-A, et seq., and is authorized thereby to enter into this Contract.

The University desires to obtain _____ (Short description of the goods and/or services to be provided) _____
_____ from the Contractor.

NOW THEREFORE, for and in consideration of the foregoing and the mutual promises hereinafter expressed and intending to be legally bound hereby, the Parties agree as follows:

TABLE OF CONTENTS

SECTION 1.	CONTRACTOR DUTIES
SECTION 2.	TERM OF CONTRACT
SECTION 3.	RENEWALS
SECTION 4.	COST OF AGREEMENT
SECTION 5.	COMPENSATION/EXPENSES

- SECTION 6. INVOICES
- SECTION 7. PAYMENT
- SECTION 8. TAXES
- SECTION 9. ASSIGNMENT OF ANTITRUST CLAIMS
- SECTION 10. OWNERSHIP RIGHTS
- SECTION 11. TERMINATION OF AGREEMENT
- SECTION 12. AUDIT PROVISIONS
- SECTION 13. CONTRACTOR RESPONSIBILITY
- SECTION 14. CONTRACTOR INTEGRITY
- SECTION 15. AMERICANS WITH DISABILITIES ACT
- SECTION 16. ASSIGNABILITY AND SUBCONTRACTING
- SECTION 17. NONDISCRIMINATION/SEXUAL HARASSMENT CLAUSE
- SECTION 18. FORCE MAJEURE
- SECTION 19. DEFAULT
- SECTION 20. HOLD HARMLESS PROVISION
- SECTION 21. CONTRACTOR CONTROVERSIES
- SECTION 22. AMENDMENTS
- SECTION 23. SEVERABILITY
- SECTION 24. APPLICABLE LAW
- SECTION 25. INDEPENDENT CONTRACTOR
- SECTION 26. POST-CONSUMER RECYCLED CONTENT *(if applicable)*
- SECTION 27. ENVIRONMENTAL PROVISIONS *(if applicable)*
- SECTION 28. HAZARDOUS SUBSTANCES *(if applicable)*
- SECTION 29. WARRANTY
- SECTION 30. COMPLIANCE WITH LAW
- SECTION 31. INTEGRATION
- SECTION 32. PATENT, COPYRIGHT AND TRADEMARK INDEMNITY *(if applicable)*
- SECTION 33. ATTACHMENTS *(if applicable)***

1. CONTRACTOR DUTIES. The Contractor, subject to the terms and conditions set forth below, shall perform the following specified duties: _____.

2. TERM OF CONTRACT. The term of the Contract shall commence on the Effective Date (as defined below) and shall end on _____, subject to the other provisions of the Contract.

The Effective Date shall be fixed by the Contracting Officer after the Contract has been fully executed by the Contractor and by the Commonwealth, and all approvals required by Commonwealth contracting procedures have been obtained. The Contract shall not be a legally binding contract until after the Effective Date is affixed and the fully-executed Contract has been sent to the Contractor.

The Contracting Officer shall issue a written Notice to Proceed to the Contractor directing the Contractor to start performance on a date which is on or after the Effective Date. The Contractor shall not start the performance of any work prior to the date set forth in the Notice to Proceed and the Commonwealth shall not be liable to pay the Contractor for any service or work performed or expenses incurred before the date set forth in the Notice to Proceed. No agency employee has the authority to verbally direct the commencement of any work under this Contract.

The Commonwealth reserves the right, upon notice to the Contractor, to extend the term of the Contract for up to three (3) months upon the same terms and conditions. This will be utilized to prevent a lapse in Contract coverage and only for the time necessary, up to three (3) months, to enter into a new contract.

3. RENEWALS. _____.

4. COST OF AGREEMENT. It is understood that the cost of this Agreement to the University shall not exceed _____. **(Note that this is the maximum amount of this contract and is not a guaranteed payment. The University shall only pay for actual services rendered.)**

5. COMPENSATION/EXPENSES. The Contractor shall be required to perform the specified services at the price(s) quoted in the Contract. All services shall be performed within the time period(s) specified in the Contract. The Contractor shall be compensated only for work performed to the satisfaction of the Commonwealth. The Contractor shall not be allowed or paid **travel or per diem expenses except as specifically set forth in the Contract.**

5.1 *Conditional Price Escalations.*

Price increases may be tolerated if in accordance with the following statements:

Escalation of annual costs for subsequent years of this contract is not automatic and shall not exceed inflation guidelines as established by the nationally accepted Consumer Price Index-Urban (CPI) for each year for this particular commodity or service. Contractor must provide documentation to justify escalation and make escalation request in writing on an annual basis.

Should escalation figures prove to be above CPI levels, the contractor must provide sufficient justification for the increase and said increase must be acceptable to the University. Newly negotiated labor agreements, federally recognized fuel inflation adjustments, statutory increases, and applicable federal and state wage laws are acceptable increases which may exceed CPI levels.

6. INVOICES. The Contractor shall send an itemized invoice to the "Provide Service and Bill To" address promptly after services are satisfactorily completed. The invoice should include only amounts due under the Contract. The Contract inquiry number shall be included on all invoices.

7. PAYMENT. (A) The Commonwealth shall put forth reasonable efforts to make payment by the required payment date. The required payment date is: (a) the date on which payment is due under the terms of the Contract; (b) thirty (30) days after a proper invoice actually is received at the "Provide Service and Bill To" address if a date on which payment is due is not specified in the Contract (a "proper" invoice is not received until the Commonwealth accepts the service as satisfactorily performed); or (c) the payment date specified on the invoice if later than the dates established by (a) and (b) above. Payment may be delayed if the payment amount on an invoice is not based on the price(s) as stated in the Contract. If any payment is not made within fifteen (15) days after the required payment date, the Commonwealth may pay interest as determined by the Secretary of Budget in accordance with Act No. 266 of 1982 and regulations promulgated pursuant thereto. Payment should not be construed by the Contractor as acceptance of the service performed by the Contractor. The Commonwealth reserves the right to conduct further testing and inspection after payment, but within a reasonable time after performance, and to reject the service if such post payment testing or inspection discloses a defect or a failure to meet specifications. The Contractor agrees that the Commonwealth may set off the amount of any state tax liability or other obligation of the Contractor or its subsidiaries to the Commonwealth against any payments due the Contractor under any contract with the Commonwealth.

(B) The Commonwealth shall have the option of using the Commonwealth purchasing card to make purchases under the Contract or purchase order. The Commonwealth's purchasing card is similar to a credit card in that there will be a small fee which the Contractor will be required to pay and the Contractor will receive payment directly from the card issuer rather than the Commonwealth. Any and all fees related to this type of payment are the responsibility of the Contractor. In no case will the Commonwealth allow increases in prices to offset credit card fees paid by the Contractor or any other charges incurred by the Contractor, unless specifically state

in the terms of the Contract or purchase order.

8. TAXES. The Commonwealth is exempt from all excise taxes imposed by the Internal Revenue Service and has accordingly registered with the Internal Revenue Service to make tax free purchases under Registration No. 2374001-K. With the exception of purchases of the following items, no exemption certificates are required and none will be issued: undyed diesel fuel, tires, trucks, gas guzzler emergency vehicles and sports fishing equipment. The Commonwealth is also exempt from Pennsylvania state sales tax, local sales tax, public transportation assistance taxes and fees and vehicle rental tax. The Department of Revenue regulations provide that exemption certificates are not required for sales made to governmental entities and none will be issued. Nothing in this paragraph is meant to exempt a construction contractor from the payment of any of these taxes or fees which are required to be paid with respect to the purchase, use, rental, or lease of tangible personal property or taxable services used or transferred in connection with the performance of a construction contract.

9. ASSIGNMENT OF ANTITRUST CLAIMS. The Contractor and the Commonwealth recognize that in actual economic practice, overcharges by the Contractor's suppliers resulting from violations of state or federal antitrust laws are in fact borne by the Commonwealth. As part of the consideration for the award of the Contract, and intending to be legally bound, the Contractor assigns to the Commonwealth all right, title and interest in and to any claims the Contractor now has, or may acquire, under state or federal antitrust laws relating to the products and services which are the subject of the Contract.

10. OWNERSHIP RIGHTS. The Commonwealth shall have unrestricted authority to reproduce, distribute, and use any submitted report, data or material, and any software or modifications and any associated documentation that is designed or developed and delivered to the Commonwealth as part of the performance of the Contract.

11. TERMINATION OF AGREEMENT. The Commonwealth has the right to terminate the Contract for any of the following reasons. Termination shall be effective upon written notice to the Contractor:

(a) Termination for Convenience. The Commonwealth shall have the right to terminate the Contract for its convenience if the Commonwealth determines termination to be in its best interest. The Contractor shall be paid for work satisfactorily completed prior to the effective date of the termination, but in no event shall the Contractor be entitled to recover lost profits.

(b) Non-appropriation. The Commonwealth's obligation to make payments during any Commonwealth fiscal year succeeding the current fiscal year shall be subject to availability and appropriation of funds. When funds (state and/or federal) are not appropriated or otherwise made available to support continuation of performance in a subsequent fiscal year period, the Commonwealth shall have the right to terminate the Contract. The Contractor shall be reimbursed for the reasonable value of any nonrecurring costs incurred but not amortized in the price of the supplies or services delivered under this Contract. Such reimbursement shall not include loss of profit, loss of use of money, or administrative or overhead costs. The reimbursement amount may be paid from any appropriations available for that purpose.

(c) Termination for Cause. The Commonwealth shall have the right to terminate the Contract for Contractor default under paragraph 19, Default, upon written notice to the Contractor. The Commonwealth shall also have the right, upon written notice to the Contractor, to terminate the Contract for other cause as specified in this Contract or by law. If it is later determined that the Commonwealth erred in terminating the Contract for cause, then, at the Commonwealth's discretion, the Contract shall be deemed to have been terminated for convenience under subparagraph (a).

12. AUDIT PROVISIONS. The Commonwealth shall have the right, at reasonable times and at a site designated by the Commonwealth, to audit the books, documents and records of the Contractor to the extent that the books, documents and records relate to costs or pricing

data for the Contract. The Contractor agrees to maintain records which will support the prices charged and costs incurred for the Contract.

The Contractor shall preserve books, documents and records that relate to costs or pricing data for the Contract for a period of three (3) years from date of final payment. The Contractor shall give full and free access to all records to the Commonwealth and/or their authorized representatives.

13. CONTRACTOR RESPONSIBILITY.

(a) The Contractor certifies for itself and all its subcontractors, that as of the date of its execution of this Bid/Contract, that neither the Contractor, nor any subcontractors, nor any suppliers are under suspension or debarment by the Commonwealth, or any governmental entity, instrumentality, or authority and, if the Contractor cannot so certify, then it agrees to submit, along with its Bid, a written explanation of why such certification cannot be made.

(b) The Contractor also certifies, that as of the date of its execution of this Bid/Contract, it has no tax liabilities or other Commonwealth obligations.

(c) The Contractor's obligations pursuant to these provisions are ongoing from and after the effective date of the contract through the termination date thereof. Accordingly, the Contractor shall have an obligation to inform the Commonwealth if, at any time during the term of the Contract, it becomes delinquent in the payment of taxes, or other Commonwealth obligations, or if it or any of its subcontractors are suspended or debarred by the Commonwealth, the federal government, or any other state or governmental entity. Such notification shall be made within 15 days of the date of suspension or debarment.

(d) The failure of the Contractor to notify the Commonwealth of its suspension or debarment by the Commonwealth, any other state, or the federal government shall constitute an event of default of the Contract with the Commonwealth.

(e) The Contractor agrees to reimburse the Commonwealth for the reasonable costs of investigation incurred by the Office of State Inspector General for investigations of the Contractor's compliance with terms of the Contract or any other agreement between the Contractor and the Commonwealth which result in the suspension or debarment of the Contractor. Such costs shall include, but not be limited to, salaries of investigators, including overtime; travel and lodging expenses; and expert witnesses and documentary fees. The Contractor shall not be responsible for investigative costs for investigations which do not result in the Contractor's suspension or debarment.

(f) The Contractor may obtain a current list of suspended and debarred Commonwealth Contractors by either searching the internet at <http://www.dgs.state.pa.us/debarment.htm> or contacting the:

Department of General Services
Office of Chief Counsel
603 North Office Building
Harrisburg, PA 17125
Telephone No. (717) 783-6472; Fax No. (717) 787-9138

All Contractors (if a corporate entity both signatories to this Contract must execute) with the State System shall sign the certification below:

Contractor Responsibility Certification

I certify that I, the Contractor identified herein, am not currently debarred or suspended by the Commonwealth of Pennsylvania, and am eligible to contract with the Commonwealth of Pennsylvania for the goods and/or services contained in this contract.

SAMPLE
Contractor/Vendor _____ Title _____

Date

SAMPLE
Contractor/Vendor _____ Title _____

Date

ALL PARTIES WHO SIGN THIS CONTRACT ON BEHALF OF THE CONTRACTOR MUST SIGN THE STATEMENT ABOVE.

14. CONTRACTOR INTEGRITY.

(a) For purposes of this clause only, the words "confidential information," "consent," "Contractor," "financial interest," and "gratuity" shall have the following definitions:

1) *Confidential information* means information that is not public knowledge, or available to the public on request, disclosure of which would give an unfair, unethical, or illegal advantage to another desiring to contract with the Commonwealth.

2) *Consent* means written permission signed by a duly authorized officer or employee of the Commonwealth, provided that where the material facts have been disclosed, in writing, by prequalification, bid, proposal, or contractual terms, the Commonwealth shall be deemed to have consented by virtue of execution of this agreement.

3) *Contractor* means the individual or entity that has entered into the Contract with the Commonwealth, including directors, officers, partners, managers, key employees and owners of more than a 5% interest.

4) *Financial Interest* means:

(a) Ownership of more than a 5% interest in any business;

or

(b) Holding a position as an officer, director, trustee, partner, employee, or the like, or holding any position of management.

5) *Gratuity* means any payment of more than nominal monetary value in the form of cash, travel, entertainment, gifts, meals, lodging, loans, subscriptions, advances, deposits of money, services, employment, or contracts of any kind.

(b) The Contractor shall maintain the highest standards of integrity in the performance of the Contract and shall take no action in violation of state or federal laws, regulations, or other requirements that govern contracting with the Commonwealth.

(c) The Contractor shall not disclose to others any confidential information gained by virtue of the Contract.

(d) The Contractor shall not, in connection with this or any other agreement with the Commonwealth, directly or indirectly, offer, confer, or agree to confer any pecuniary benefit on anyone as consideration for the decision, opinion, recommendation, vote, other exercise of discretion, or violation of a known legal duty by any officer or employee of the Commonwealth.

(e) The Contractor shall not, in connection with this or any other agreement with the Commonwealth, directly or indirectly, offer, give, or agree to promise to give to anyone any gratuity for the benefit of or at the direction or request of any officer or employee of the Commonwealth.

(f) Except with the consent of the Commonwealth, neither the Contractor nor anyone in privity with him or her shall accept or agree to accept from, or give or agree to give to, any person, any gratuity from any person in connection with the performance of work under the Contract except as provided therein.

(g) Except with the consent of the Commonwealth, the Contractor shall not have a financial interest in any other contractor, subcontractor, or supplier providing services, labor, or material on this project.

(h) The Contractor, upon being informed that any violation of these provisions has occurred or may occur, shall immediately notify the Commonwealth in writing.

(i) The Contractor, by execution of the Contract and by the submission of any bills or invoices for payment pursuant thereto, certifies and represents that he or she has not violated any of these provisions.

(j) The Contractor, upon the inquiry or request of the Inspector General of the Commonwealth or any of that official's agents or representatives, shall provide, or if appropriate, make promptly available for inspection and copying, any information of any type or form deemed relevant by the Inspector General to the Contractor's integrity or responsibility, as those terms are defined by the Commonwealth's statutes, regulations, or management directives. Such information may include, but shall not be limited to, the Contractor's business or financial records, documents and files of any type or form which refers to or concern the Contract. Such information shall be retained by the Contractor for a period of three years beyond the termination of the Contract unless otherwise provided by law.

(k) For violation of any of the above provisions, the Commonwealth may terminate this and any other agreement with the Contractor, claim liquidated damages in an amount equal to the value of anything received in breach of these provisions, claim damages for all expenses incurred in obtaining another Contractor to complete performance hereunder, and debar and suspend the Contractor from doing business with the Commonwealth. These rights and remedies are cumulative, and the use or nonuse of any one shall not preclude the use of all or any other. These rights and remedies are in addition to those the Commonwealth may have under law, statute, regulation, or otherwise.

15. AMERICANS WITH DISABILITIES ACT.

(a) Pursuant to Federal Regulations promulgated under the authority of The Americans with Disabilities Act, 28 C.F.R. § 35.101, et seq., the Contractor understands and agrees that it shall not cause any individual with a disability to be excluded from participation in this Contract or from activities provided for under this Contract on the basis of the disability. As a condition of accepting this Contract, the Contractor agrees to comply with the "General Prohibitions Against Discrimination," 28 C.F.R. §35.130, and all other regulations promulgated

under Title II of The American with Disabilities Act which are applicable to all benefits, services, programs, and activities provided by the Commonwealth of Pennsylvania through contracts with outside contractors.

(b) The Contractor shall be responsible for and agrees to indemnify and hold harmless the Commonwealth of Pennsylvania from all losses, damages, expenses, claims, demands, suits and actions brought by any party against the Commonwealth of Pennsylvania as a result of the Contractor's failure to comply with the provisions of subparagraph (a) above.

16. ASSIGNABILITY AND SUBCONTRACTING.

(a) Subject to the terms and conditions of Paragraph 21, this Contract shall be binding upon the parties and their respective successors and assigns.

(b) The Contractor shall not subcontract with any person or entity to perform all or any part of the work to be performed under this Contract without the prior written consent of the Contracting Officer, which consent may be withheld at the sole and absolute discretion of the Contracting Officer.

(c) The Contractor may not assign, in whole or in part, this Contract or its rights, duties, obligations, or responsibilities hereunder without the prior written consent of the Contracting Officer, which consent may be withheld at the sole and absolute discretion of the Contracting Officer.

(d) Notwithstanding the foregoing, the Contractor may, without the consent of the Contracting Officer, assign its rights to payment to be received under the Contract, provided that the Contractor provides written notice of such assignment to the Contracting Officer together with a written acknowledgement from the assignee that any such payments are subject to all the terms and conditions of the Contract.

(e) For the purposes of this Contract, the term "assign" shall include, but shall not be limited to, the sale, gift, assignment, pledge, or other transfer of any ownership interest in the Contractor, provided, however, that the term shall not apply to the sale or other transfer of stock of a publicly traded company.

(f) Any assignment consented to by the Contracting Officer shall be evidenced by a written assignment agreement executed by the Contractor and its assignee in which the assignee agrees to be legally bound by all of the terms and conditions of the Contract and to assume the duties, obligations, and responsibilities being assigned.

(g) A change of name by the Contractor, following which the Contractor's federal identification number remains unchanged, shall not be considered to be an assignment hereunder. The Contractor shall give the Contracting Officer written notice of any such change of name.

17. NONDISCRIMINATION/SEXUAL HARASSMENT CLAUSE.

During the term of the Contract, Contractor agrees as follows:

(a) In the hiring of any employees for the manufacture of supplies, performance of work, or any other activity required under the Contract or any subcontract, the Contractor, subcontractor or any person acting on behalf of the Contractor or subcontractor shall not by reason of gender, race, creed, color discriminate against any citizen of this Commonwealth who is qualified and available to perform the work to which the employment relates.

(b) Neither the Contractor nor any subcontractor nor any person on their behalf shall

in any manner discriminate against or intimidate any employee involved in the manufacture of supplies, the performance of work or any other activity required under the Contract on account of gender, race, creed, color.

(c) Contractors and any subcontractors shall establish and maintain a written sexual harassment policy and shall inform their employees of the policy. The policy must contain a notice that sexual harassment will not be tolerated and employees who practice it will be disciplined.

(d) The Contractor shall not discriminate by reason of gender, race, creed, or color against any subcontractor or supplier who is qualified to perform the work to which the contract relates.

(e) The Contractor and each subcontractor shall furnish all necessary employment documents and records to and permit access to its books, records, and accounts by the Contracting Officer and the Department of General Services' Bureau of Contract Administration and Business Development for purposes of investigation to ascertain compliance with the provisions of this Nondiscrimination/Sexual Harassment Clause. If the Contractor or any subcontractor does not possess documents or records reflecting the necessary information requested, it shall furnish such information on reporting forms supplied by the Contracting Officer or the Bureau of Contract Administration and Business Development.

(f) The Contractor shall include the provisions of this Nondiscrimination/Sexual Harassment Clause in every subcontract so that such provisions will be binding upon each subcontractor.

(g) The Commonwealth may cancel or terminate the Contract, and all money due or to become due under the Contract may be forfeited for a violation of the terms and conditions of this Nondiscrimination/Sexual Harassment Clause. In addition, the agency may proceed with debarment or suspension and may place the Contractor in the Contractor Responsibility File.

18. FORCE MAJEURE. Neither party will incur any liability to the other if its performance of any obligation under this Contract is prevented or delayed by causes beyond its control and without the fault or negligence of either party. Causes beyond a party's control may include, but are not limited to, acts of God or war, changes in controlling law, regulations, orders or the requirements of any governmental entity, severe weather conditions, civil disorders, natural disasters, fire, epidemics and quarantines, general strikes throughout the trade, and freight embargoes.

The Contractor shall notify the Commonwealth orally within five (5) days and in writing within ten (10) days of the date on which the Contractor becomes aware, or should have reasonably become aware, that such cause would prevent or delay its performance. Such notification shall (i) describe fully such cause(s) and its effect on performance, (ii) state whether performance under the Contract is prevented or delayed, and (iii) if performance is delayed, state a reasonable estimate of the duration of the delay. The Contractor shall have the burden of proving that such cause(s) delayed or prevented its performance despite its diligent efforts to perform and shall produce such supporting documentation as the Commonwealth may reasonably request. After receipt of such notification, the Commonwealth may elect either to cancel the Contract or to extend the time for performance as reasonably necessary to compensate for the Contractor's delay.

In the event of a declared emergency by competent governmental authorities, the Commonwealth, by notice to the Contractor, may suspend all or a portion of the Contract.

19. DEFAULT.

(a) The Commonwealth may, subject to the provisions of Paragraph 18, Force Majeure, and in addition to its other rights under the Contract, declare the Contractor in default by written notice thereof to the Contractor, and terminate (as provided in Paragraph 11, Termination of Agreement) the whole or any part of this Contract for any of the following reasons:

- 1) Failure to begin work within the time specified in the Contract or as otherwise specified;
- 2) Failure to perform the work with sufficient labor, equipment, or material to insure the completion of the specified work in accordance with the Contract terms;
- 3) Unsatisfactory performance of the work;
- 4) Failure or refusal to remove material, or remove and replace any work rejected as defective or unsatisfactory;
- 5) Discontinuance of work without approval;
- 6) Failure to resume work, which has been discontinued, within a reasonable time after notice to do so;
- 7) Insolvency or bankruptcy;
- 8) Assignment made for the benefit of creditors;
- 9) Failure or refusal within 10 days after written notice by the Contracting Officer, to make payment or show cause why payment should not be made, of any amounts due for materials furnished, labor supplied or performed, for equipment rentals, or for utility services rendered;
- 10) Failure to protect, to repair, or to make good any damage or injury to property; or
- 11) Breach of any provision of this Contract.

(b) In the event that the Commonwealth terminates this Contract in whole or in part as provided in Subparagraph (a) above, the Commonwealth may procure, upon such terms and in such manner as it determines, services similar or identical to those so terminated, and the Contractor shall be liable to the Commonwealth for any reasonable excess costs for such similar or identical services included within the terminated part of the Contract.

(c) If the Contract is terminated as provided in Subparagraph (a) above, the Commonwealth, in addition to any other rights provided in this paragraph, may require the Contractor to transfer title and deliver immediately to the Commonwealth in the manner and to the extent directed by the Issuing Office, such partially completed work, including, where applicable, reports, working papers, and other documentation, as the Contractor has specifically produced or specifically acquired for the performance of such part of the Contract as has been terminated. Except as provided below, payment for completed work accepted by the Commonwealth shall be at the Contract price. Except as provided below, payment for partially completed work including, where applicable, reports and working papers, delivered to and accepted by the Commonwealth shall be in an amount agreed upon by the Contractor and Contracting Officer. The Commonwealth may withhold from amounts otherwise due to the Contractor for such completed or partially completed works, such sums as the Contractor Officer

determines to be necessary to protect the Commonwealth against loss.

(d) The rights and remedies of the Commonwealth provided in this paragraph shall not be exclusive and are in addition to any other rights and remedies provided by law or under this Contract.

(e) The Commonwealth's failure to exercise any rights or remedies provided in this paragraph shall not be construed to be a waiver by the Commonwealth of its rights and remedies in regard to the event of default or any succeeding event of default.

(f) Following exhaustion of the Contractor's administrative remedies as set forth in Paragraph 21, the Contractor's exclusive remedy shall be to seek damages in the Board of Claims.

20. HOLD HARMLESS PROVISION. The Contractor shall hold the Commonwealth harmless from and indemnify the Commonwealth against any and all claims, demands and actions based upon or arising out of any activities performed by the Contractor and its employees and agents under this Contract and shall, at the request of the Commonwealth, defend any and all actions brought against the Commonwealth based upon any such claims or demands.

21. CONTRACT CONTROVERSIES. In the event of a controversy or claim arising from the Contract, the Contractor must, within six months after the cause of action accrues, file a written notice of controversy or claim with the Contracting Officer for a determination. The Contracting Officer shall send his/her written determination to the Contractor. The decision of the Contracting Officer shall be final and conclusive unless, within thirty (30) days after receipt of such written determination, the Contractor files a claim with the Commonwealth Board of Claims. Pending a final judicial resolution of a controversy or claim, the Contractor shall proceed diligently with the performance of the Contract in a manner consistent with the interpretation of the Contracting Officer and the Commonwealth shall compensate the Contractor pursuant to the terms of the Contract.

22. AMENDMENTS. This Agreement represents the complete agreement between the parties, superceding any other prior or contemporaneous written or oral agreements. Any changes, corrections or additions to this Agreement shall be in writing in the form of a supplemental agreement signed by all necessary parties and setting forth therein the proposed change, correction or addition.

23. SEVERABILITY. Should any term of this Contract be rendered unlawful by a court of competent jurisdiction or any legislative act, then the parties shall give effect to the balance of the agreement to the extent possible.

24. APPLICABLE LAW. This Contract shall be governed by and interpreted and enforced in accordance with the laws of the Commonwealth of Pennsylvania (without regard to any conflict of laws provisions) and the decisions of the Pennsylvania courts. The Contractor consents to the jurisdiction of any court of the Commonwealth of Pennsylvania and any federal courts in Pennsylvania, waiving any claim or defense that such forum is not convenient or proper. The Contractor agrees that any such court shall have in personam jurisdiction over it, and consents to service of process in any manner authorized by Pennsylvania law.

25. INDEPENDENT CONTRACTOR. In performing the services required by the Contract, the Contractor will act as an independent Contractor and not as an employee or agent of the Commonwealth.

26. POST-CONSUMER RECYCLED CONTENT. (*if applicable*) Except as specifically waived by the Department of General Services in writing, any products which are provided to the Commonwealth as a part of the performance of the Contract must meet the minimum percentage levels for the total recycled content as specified in Exhibits A-1 through A-3 to this Contract.

27. ENVIRONMENTAL PROVISIONS. (if applicable) In the performance of the Contract, the Contractor shall minimize pollution and shall strictly comply with all applicable environmental laws and regulations.

28. HAZARDOUS SUBSTANCES. (if applicable) The Contractor shall provide information to the Commonwealth about the identity and hazards of hazardous substances supplied or used by the Contractor in the performance of the Contract. The Contractor must comply with Act 159 of October 5, 1984, known as the "Worker and Community Right to Know Act" (the "Act") and the regulations promulgated pursuant thereto at 4 Pa. Code § 301.1 et seq.

(a) Labeling. The Contractor shall insure that each individual product (as well as the carton, container or package in which the product is shipped) of any of the following substances (as defined by the Act and the regulations) supplied by the Contractor is clearly labeled, tagged or marked with the information listed in Paragraph (1) through (4) below:

- 1) Hazardous substances:
 - a) The chemical name or common name,
 - b) A hazard warning, and
 - c) The name, address, and telephone number of the manufacturer.
- 2) Hazardous mixtures:
 - a) The common name, but if none exists, then the trade name,
 - b) The chemical or common name of special hazardous substances comprising .01% or more of the mixture,
 - c) The chemical or common name of hazardous substances consisting of 1.0% or more of the mixture,
 - d) A hazard warning, and
 - e) The name, address, and telephone number of the manufacturer.
- 3) Single Chemicals:
 - a) The chemical name or the common name,
 - b) A hazard warning, if appropriate, and
 - c) The name, address and telephone number of the manufacturer.
- 4) Chemical Mixtures:
 - a) The common name, but if none exists, then the trade name,
 - b) A hazard warning, if appropriate,
 - c) The name, address, and telephone number of the manufacturer, and
 - d) The chemical name or common name of either the top five substances by volume or those substances consisting of 5.0% or more of the mixture.

A common name or trade name may be used only if the use of the name more easily or readily identifies the true nature of the hazardous substance, hazardous mixture, single chemical, or mixture involved.

Container labels shall provide a warning as to the specific nature of the hazard arising from the substance in the container.

The hazard warning shall be given in conformity with one of the nationally recognized and accepted systems of providing warnings, and hazard warnings shall be consistent

with one or more of the recognized systems throughout the workplace. Examples are:

- ¾ NFPA 704, identification of the Fire Hazards of Materials.
- ¾ National Paint and Coatings Association: Hazardous Materials Identification System.
- ¾ American Society for Testing Materials, Safety Alert Pictorial Chart.
- ¾ American National Standard Institute, Inc., for the Precautionary Labeling of Hazardous Industrial Chemicals.

Labels must be legible and prominently affixed to and displayed on the product and the carton, container, or package so that employees can easily identify the substance or mixture present therein.

(b) **Material Safety Data Sheet.** The Contractor shall provide Material Safety Data Sheets (MSDS) with the information required by the Act and the regulations for each hazardous substance or hazardous mixture. The Commonwealth must be provided an appropriate MSDS with the initial shipment and with the first shipment after an MSDS is updated or product changed. For any other chemical, the Contractor shall provide an appropriate MSDS, if the manufacturer, importer, or supplier produces or possesses the MSDS. The Contractor shall also notify the Commonwealth when a substance or mixture is subject to the provisions of the Act. Material Safety Data Sheets may be attached to the carton, container, or package mailed to the Commonwealth at the time of shipment.

29. **WARRANTY.** The Contractor warrants that all services performed by the Contractor, its agents and subcontractors shall be free and clear of any defects in workmanship or materials. Unless otherwise stated in the Contract, all services and parts are warranted for a period of one year following completion of performance by the Contractor and acceptance by the Commonwealth. The Contractor shall correct any problem with the service and/or replace any defective part with a part of equivalent or superior quality without any additional cost to the Commonwealth.

30. **COMPLIANCE WITH LAW.** The Contractor shall comply with all applicable federal and state laws and regulations and local ordinances in the performance of the Contract.

31. **INTEGRATION.** The Contract including all referenced documents, constitutes the entire agreement between the parties. No agent, representative, employee or officer of either the Commonwealth or the Contractor has the authority to make, or has made, any statement, agreement or representation, oral or written, in connection with the Contract, which in any way can be deemed to modify, add to and detract from, or otherwise change or alter its terms and conditions. No negotiations between the parties, nor any custom or usage, shall be permitted to modify or contradict any of the terms and conditions of the Contract. No modifications, alterations, changes, or waiver to the Contract or any of its terms shall be valid or binding unless accomplished by a written amendment signed by both parties. All such amendments shall be made using the appropriate Commonwealth form.

32. **PATENT, COPYRIGHT AND TRADEMARK INDEMNITY.** *(if applicable)* The Contractor warrants that it is the sole owner or author of, or has entered into a suitable legal agreement concerning either: a) the design of any product or process provided or used in the performance of the Contract which is covered by a patent, copyright, or trademark registration or other right duly authorized by state or federal law or b) any copyrighted matter in any report document or other material provided to the Commonwealth under the Contract. The Contractor shall defend any suit or proceeding brought against the Commonwealth on account of any alleged patent, copyright or trademark infringement in the United States of any of the products provided or used in the performance of the Contract. This is under the condition that the Commonwealth shall provide prompt notification in writing of such suit or proceedings; full right, authorization and opportunity to conduct the defense thereof; and full information and all reasonable cooperation in the defense of same. As principles of governmental or public law are involved,

the Commonwealth may participate in or choose to conduct, in its sole discretion, the defense of any such action. If information and assistance are furnished by the Commonwealth at the Contractor's written request, it shall be at the Contractor's expense, but the responsibility for such expense shall be only that within the Contractor's authorization.

The Contractor shall indemnify and hold the Commonwealth harmless from all damages, costs, and expenses, including attorney's fees that the Contractor or the Commonwealth may pay or incur by reason of any infringement or violation of the rights occurring to any holder of copyright, trademark, or patent interests and rights in any products provided or used in the performance of the Contract. If any of the products provided by the Contractor in such suit or proceedings are held to constitute infringement and the use is enjoined, the Contractor shall, at its own expense and at its option, either procure the right to continue use of such infringement products, replace them with non-infringement equal performance products or modify them so that they are no longer infringing. If the Contractor is unable to do any of the preceding, the Contractor agrees to remove all the equipment or software which are obtained contemporaneously with the infringing product, or, at the option of the Commonwealth, only those items of equipment or software which are held to be infringing, and to pay the Commonwealth: 1) any amounts paid by the Commonwealth towards the purchase of the product, less straight line depreciation; 2) any license fee paid by the Commonwealth for the use of any software, less an amount for the period of usage; and 3) the pro rata portion of any maintenance fee representing the time remaining in any period of maintenance paid for. The obligations of the Contractor under this paragraph continue without time limit. No costs or expenses shall be incurred for the account of the Contractor without its written consent.

THE REMAINDER OF THIS PAGE HAS BEEN INTENTIONALLY LEFT BLANK.

IN WITNESS WHEREOF, the parties hereto have caused this Agreement to be executed pursuant to due and legal action authorizing the same to be done the date first written above.

FOR THE CONTRACTOR:

SAMPLE

Individual or Partner (if Contractor
is an individual or partnership)

SAMPLE

Title

SAMPLE

President or Vice President of
Corporate Contractor
(Circle Title)

SAMPLE

Secretary or Treasurer of
Corporate Contractor
(Circle Title)

Note regarding signatures above. If a corporation, two
signatures are required, one being the President or

*Vice President, the second being the Secretary or Treasurer.
Signatory authority of either signatures can be delegated
provided there is a certified Board resolution presented
with this contract.*

**ALL SIGNATORIES ON BEHALF
OF CONTRACTOR MUST EXECUTE
CONTRACTOR RESPONSIBILITY
CERTIFICATION IN PARAGRAPH 13(d)
OF THIS CONTRACT.**

FOR THE UNIVERSITY:

Vice President of
Finance and Administration
Clarion University of Pennsylvania
State System of Higher Education

**APPROVED AS TO FISCAL
RESPONSIBILITY, BUDGETARY
APPROPRIATENESS AND
AVAILABILITY OF FUNDS**

Comptroller

APPROVED AS TO FORM AND LEGALITY

University Legal Counsel

Deputy Attorney General

CONTRACT
EFFECTIVE DATE